

# Fault Ride Through Study Assumptions for Grid Zone 7

Additional Information for the GZ 7 (Bunnythorpe Region)

**Version: 2.1**

**Date: 22/06/2026**

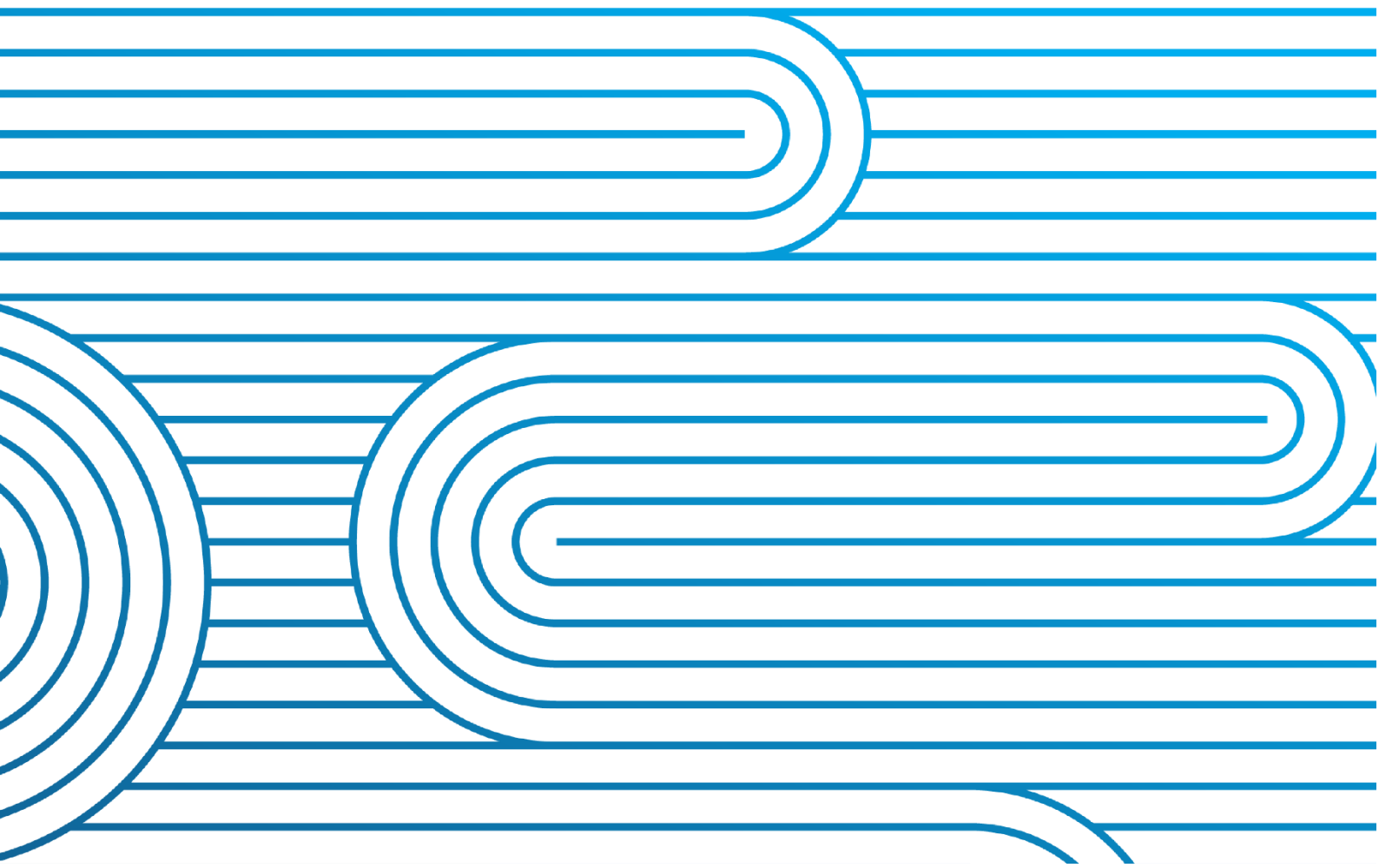

Version	Date	Change
1.0	25/08/2025	Initial Release
2.0	10/10/2025	Update sections 7.1 and 7.2
2.1	22/06/2026	Updated section 3.2

	Name & Position
Prepared By:	Power Systems Group
Reviewed By:	Power Systems Group

---

## IMPORTANT

---

### Disclaimer

The information in this document is provided in good-faith and represents the opinion of Transpower New Zealand Limited, as the System Operator, at the date of publication. Transpower New Zealand Limited does not make any representations, warranties or undertakings either express or implied, about the accuracy or the completeness of the information provided. The act of making the information available does not constitute any representation, warranty or undertaking, either express or implied. This document does not and is not intended to; create any legal obligation or duty on Transpower New Zealand Limited. To the extent permitted by law, no liability (whether in negligence or other tort, by contract, under statute or in equity) is accepted by Transpower New Zealand Limited by reason of, or in connection with, any statement made in this document or by any actual or purported reliance on it by any party. Transpower New Zealand Limited reserves all rights, in its absolute discretion, to alter any of the information provided in this document.

### Copyright

The concepts and information contained in this document are the property of Transpower New Zealand Limited. Reproduction of this document in whole or in part without the written permission of Transpower New Zealand is prohibited.

### Contact Details

Address: Transpower New Zealand Ltd  
 Waikoukou - 22 Boulcott St  
 PO Box 1021  
 Wellington  
 New Zealand

Telephone: +64 4 495 7000

Email: [system.operator@transpower.co.nz](mailto:system.operator@transpower.co.nz)

Website: <http://www.transpower.co.nz>

---

---

---

# Contents

<b>1</b>	<b>Introduction</b> .....	<b>4</b>
1.1	Additional documents.....	5
<b>2</b>	<b>FRT Study Purpose</b> .....	<b>6</b>
<b>3</b>	<b>System Conditions</b> .....	<b>7</b>
3.1	System model.....	7
3.2	Network model .....	7
3.3	System voltages.....	8
3.4	PCC groups classification.....	9
3.5	Transmission circuit outages .....	9
<b>4</b>	<b>Local Conditions</b> .....	<b>12</b>
4.1	Local network model.....	12
4.2	Generator model.....	12
<b>5</b>	<b>Other Generation</b> .....	<b>14</b>
<b>6</b>	<b>Relevant External Conditions</b> .....	<b>14</b>
<b>7</b>	<b>Fault Conditions</b> .....	<b>15</b>
7.1	Fault types.....	15
7.2	Fault clearance times .....	15
7.3	Fault locations .....	15
7.4	Over-voltage simulations .....	17
<b>Appendix: Site Codes</b> .....		<b>18</b>

# 1 Introduction

Fault Ride-Through (FRT) is the ability of a generating unit to stay connected to the electrical grid during and following a fault disturbance, and then then to provide active power at least proportional to the grid voltage. This document provides additional information and system assumptions relevant to the Grid Zone 7 (Bunnythorpe Region ) for the technical studies required to demonstrate compliance with the FRT requirements stipulated in EIPC Clause 8.25A(3).

The Bunnythorpe region includes: Bunnythorpe, Linton, Tokaanu, Rangipo, Tangiwai, Taumarunui, Wanganui, Marton, Mangahao, Woodville, Dannevirke, Waipawa, Mataroa, Ohakune, National Park, and Turitea, Tararua and Te Apiti wind farms. For a list of site code abbreviations relevant to this region, see the appendix. The contents of this document apply to any asset that will be connected within the Bunnythorpe region, which is shown geographically and as a single line diagram in Figure 1-1 and Figure 1-2.

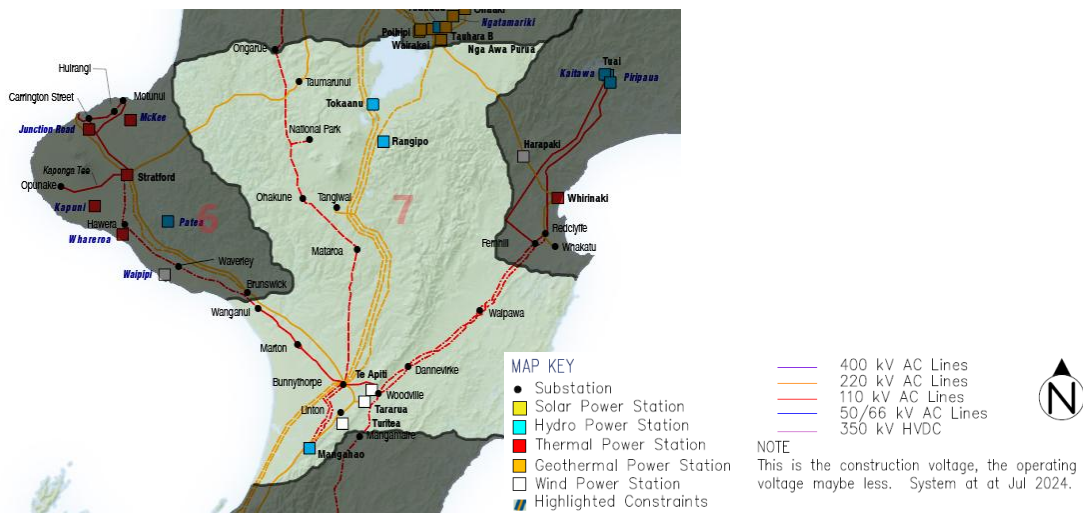

Figure 1-1 (above): Geographic representation of Bunnythorpe Region (Grid Zone 7)

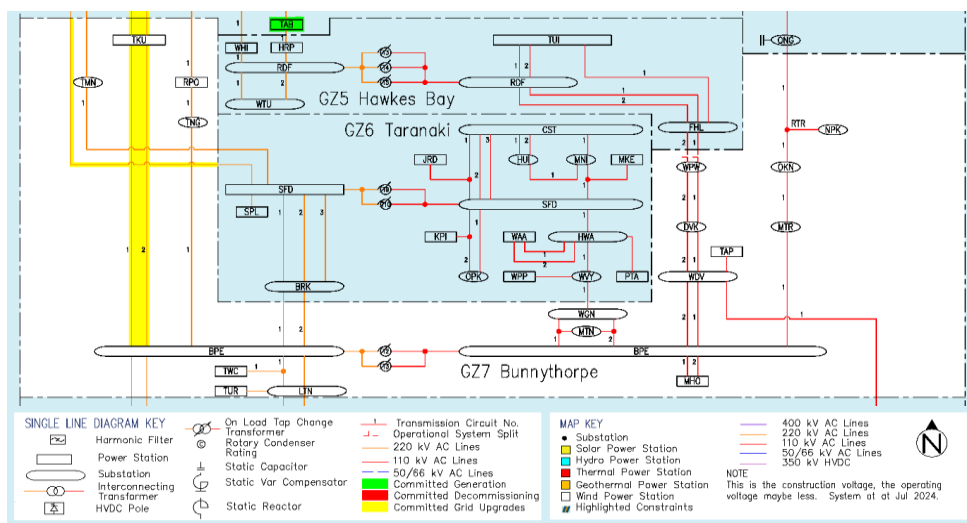

Figure 1-2: Single line diagram of Bunnythorpe Region (Grid Zone 7)

This document includes region-specific information and historical voltage trends to support you to complete your studies with accurate region-specific system conditions. You will also find an appropriate set of planned outages and corresponding generation dispatches, as well as information on any changing system conditions in the region, including the commissioning or de-commissioning of both transmission and generation assets.

Note that planned outages (section 3.5) and fault locations (section 7.3) to be studied will depend on the point of common coupling (PCC) groups. These have been introduced based on the location of the stations, with each station within the region assigned to a specific PCC group. You can find these outlined in section 3.4.

If your asset has not started commissioning one year after the System Operator has received and accepted a technical study, you may need to repeat it to reflect further changes to the power system that could affect the asset's fault ride through capability.

## 1.1 Additional documents

Transpower's [GL-EA-953](#) document outlines the general requirements for a new generating station's connection studies, including the FRT study. The System Operator expects the Asset Owner to be familiar with that document as it outlines relevant information such as steps for model and study case preparation, as well as study scope and assessment criteria.

The following Transpower documents are also relevant to this assessment:

- [2024 System Security forecast](#)
- [Transpower EA EMI DIgSILENT NIPS case](#)
- [PSCAD Electromagnetic Transients \(EMT\) network model<sup>1</sup>](#)
- [Special protection schemes](#)

---

<sup>1</sup> PSCAD network model will be provided by the SO upon request

## 2 FRT Study Purpose

The System Operator expects an FRT study to have the following outcomes:

- The generating units meet all the assessment criteria whilst riding through post-fault voltage excursions within the envelopes prescribed by the Code.
- The fault ride through strategies are detailed.
- Any non-compliant, or potentially non-compliant, behaviours are identified and explained.
- There is confirmation that no protection or control settings at the generating station would result in a breach of the fault ride through requirements. If there is any shortfall of asset capability to meet the Code requirements, you shall discuss it with the System Operator.

## 3 System Conditions

### 3.1 System model

You should perform the FRT assessment based on the latest available design parameters of your asset.

- If you modify any controller parameter after submitting the FRT report, i.e. during or after the EIPC Compliance tests, then you must also provide the System Operator with updated parameters.
- If there is a material change in the settings that would significantly alter the FRT performance, you may need to update and resubmit the study to the System Operator.

#### 3.1.1 Minimum and maximum short circuit level conditions

It is acceptable to use the winter/summer peak and light load summer scenarios provided in the Electricity Market Information (EMI) dataset to prepare the maximum and minimum short circuit level study scenarios. The LoadSeason triggers 'At regional night trough S EXP' and 'At regional night trough W EXP' (for summer and winter respectively) may also be used in the absence of a light load summer scenario for the study year in question. As a minimum, the studies should be carried out for the planned commissioning year. Your study should also include any significant future local changes if the EMI case contains that relevant data.

### 3.2 Network model

The network model used for the connecting assets in the FRT study should include an accurate representation of:

- all generation units
- generator transformers
- the internal collector network
- the grid-connected transformer
- all controllers for Inverter Based Resources, including the Plant controller, and Inverter controller. These models should include representation of any Phase Lock Loop (PLL) controls and all current controls, and
- any associated controls or equipment to be installed in the facility.
- Any control strategies that are designed to assist in riding through system fault used in IBRs

This model must align with the available single-line diagram submitted in the Asset Capability Statement (ACS). An aggregated generating station model is acceptable for wind, solar and

battery generating stations that shall include a collector system equivalent network model, as long as the model accurately reflects the performance expected of the station (see section 4.2).

Calculate the Effective Short Circuit Ratio (ESCR) at the PCC under the lowest short circuit system conditions using the latest EMI study case, the lowest short circuit system conditions are likely to be during an outage.

For synchronous generators you will need to undertake fault ride through studies with PowerFactory RMS simulations.

For Inverter Based Resources (IBR) you will need to undertake fault ride through studies with PowerFactory RMS simulations as an initial screening to cover all generation scenarios, fault types and asset operation conditions agreed with System Operator. You must then undertake a PSCAD EMT study to assess a selection of study cases identified in the screening process as agreed with System Operator.

### 3.3 System voltages

Figure 3-1 demonstrates the grid voltage profiles over the period January to December 2024 in the Bunnythorpe Region.

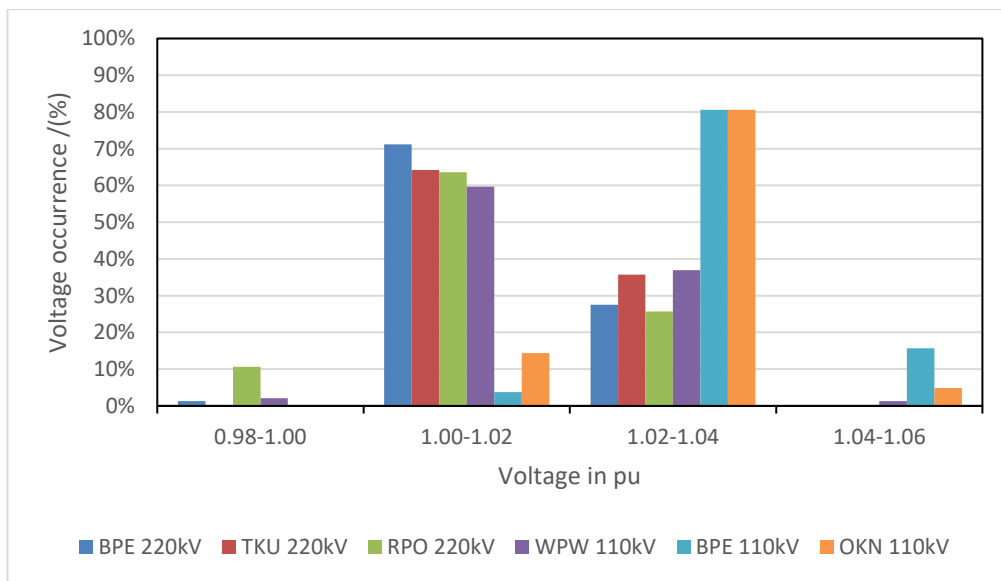

Figure 3-1: Voltage profile of BPE220kV, TKU220kV, RPO220kV, WPW110kV, BPE110kV and OKN110kV from Jan to Dec 2024

The above graph indicates that 220kV and 110kV voltage in Bunnythorpe region was mostly between 1.0-1.05 pu. Asset Owners should perform fault ride through studies with voltage targets for the region within these ranges, highlighting any impact of the new connection may have on the local voltage.

### 3.4 PCC groups classification

The System Operator has grouped 220kV and 110kV stations within the region as follows. This should help streamline the outages and fault locations to be studied based on the PCC. Accordingly, an asset connecting to any voltage level at these stations will belong to a particular PCC group.

**PCC Group A (220kV):** BPE (220kV), LTN, TWC, TUR

**PCC Group B (220kV):** RPO, TNG

**PCC Group C (220kV):** TKU

**PCC Group D (220kV):** TMN

**PCC Group E (110kV):** BPE (110kV), MHO, MTN, WGN

**PCC Group F (110kV):** MTR, OKN, NPK

**PCC Group G (110kV):** WDV, DVK, WPW, TAP

Any asset connecting to either 66kV, 33kV or lower voltage belongs to 220kV PCC group and 110kV PCC group mentioned above if particular 66kV or 33kV bus is fed directly via 220kV or 110kV bus respectively.

### 3.5 Transmission circuit outages

Planned outages are regular occurrences on the grid and the fault ride through study must include assessment of performance during outages. The System Operator expects outages to result in reduced system strength at the point of connection, which can make the fault ride through more difficult to achieve. We will maintain N-1 security during planned or forced outages, and this may require special protection schemes (SPS) or pre-contingent constraints. The generation dispatch used in the outage studies should not result in unacceptable overloading of any circuit for a further contingency. If you need advice on any relevant special protection schemes (SPS), operational measures or on specific circuit overload capabilities, contact the System Operator.

You should consider the outages in Table 3-1 and

Table 3-2 below during the FRT assessment. Table 3-1 lists the outages to be considered during the studies based on 220kV PCC groups A, B and C while

Table 3-2 lists the outages to be considered during the studies based on 110kV PCC groups D, E and F as defined in section 3.4. For 110kV PCC connections, you must also include the outage group associated with the nearest 220kV bus.

If the point of connection to the grid is at 66kV, 33kV or a lower voltage level, the outage of at least one supply transformer feeding the PCC must also be studied in addition to the below outages.

**Table 3-1: Outages under 220kV PCC groups A, B, C and D**

PCC Group A	PCC Group B	PCC Group C	PCC Group D
BPE-HAY-PRM circuit 1	BPE-TNG circuit 1	BPE-TKU circuit 1	SFD-TMN circuit 1
BPE-LTN circuit 1	TNG-RPO circuit 1	TKU-WKM circuit 1	TMN-TWH circuit 1
BPE-TKU circuit 1	RPO-WRK circuit 1	WKM-WRK circuit 1	HLY-SFD circuit 1
BPE-TNG circuit 1	WKM-WRK circuit 1	BPE-TNG circuit 1	HLY-TWH circuit 1
BPE-BRK circuit 1	OHK-WRK circuit 1		
HAY-LTN-WIL circuit 1	TAB-WRK circuit 1		
TKU-WKM circuit 1			
RPO-WRK circuit 1			
SFD-BRK circuit 1			
BPE T2			
WIL T8			

**Table 3-2: Outages under 110kV PCC groups E, F and G**

PCC Group E	PCC Group F	PCC Group G
BPE-MHO circuit 1	BPE-MTR circuit 1	BPE-WDV circuit 1
BPE-MTN-WGN circuit 1	MTR-OKN circuit 1	DVK-WPW circuit 1
WGN-WVY circuit 1	OKN-NPK-ONG circuit 1	BPE-MTR circuit 1
BPE-WDV circuit 1	ARI-HTI-ONG circuit 1*	DVK-WDV circuit 1
HWA-WVY circuit 1	BPE T2	BPE T2
BPE T2		
SFD T9		

\*need if PCC at NPK

The outages detailed above are expected to identify any problematic network configurations up to the post-fault N-1-1 condition. However, the Asset Owner remains responsible for identifying any onerous outage scenarios that result in an inability to ride through a system fault. To this end, you may choose to carry out a wider range of outage studies.

### 3.5.1 EMT studies

EMT studies should be conducted for a range of outages, with a focus on the most critical scenarios, typically the most onerous will be outages that result in the lowest short circuit ratios at the PCC. Outages in Table 3-1 and Table 3-2 can be used for screening through the SCR, in some cases not all the outages will need to be studied in the EMT case. If the point of connection to the grid is at 66 kV, 33 kV, or a lower voltage level, the outage of at least one supply transformer feeding the PCC must also be studied in addition to the above outages.

## 4 Local Conditions

### 4.1 Local network model

The network topology for Transpower assets is depicted in the EMI study case. Where there is a complex local network that can affect the study results, Asset Owners should acquire this data from the network owner and add this to the study. An equivalent representation of a local network may be sufficient.

A significant local network would, for example, be a network connected between the nearest Transpower asset and the generation site, or a network that could provide a parallel or alternative export path during any potential operation of the generation. A local network with generation that also feeds into a common connection at a Transpower asset may also need to be included.

There are a number of overload and special protection schemes in this region that need to be considered during the analysis.

BPE-MTR series reactor is normally closed. Post contingency overloading is managed by a protection scheme. This scheme will be disabled under certain outages, more information is available on the Transpower website here: [Bunnythorpe-Mataroa Circuit Overload Protection Scheme](#).

You should also consider the [Tokaanu Circuit Overload Protection Scheme](#) during a fault on the TKU-WKM 220 kV circuit. It is to be noted that this SPS only activates during a circuit tripping.

The Marton-Whanganui Circuit Overload Protection Scheme does not have any externally published information, so is summarised below.

This scheme manages the loading on MTN-WGN 1 and 2 110 kV circuit sections. The scheme detects an overload on the MTN-WGN section of BPE-MTN-WGN-1 and BPE-MTN-WGN-2 for power flow from WGN towards MTN. generation at Waipipi will be automatically reduced. If overload persists, 33 kV feeders at Waipipi Wind Farm are opened. If overload persists, Waipipi Wind Farm is disconnected from the Waverly substation.

The load model in the 2024 EMI case is set with constant impedance modelling in the transient studies, this is an optimistic assumption for the load behaviour. It is prudent to perform fault ride through studies with less optimistic load modelling (such as modelling the real power load component as constant current, or modelling both real and reactive load components as 50% constant current, 50% constant impedance) as a sensitivity.

### 4.2 Generator model

The high-level details for modelling the generation facility are available in the [GL-EA-953](#) guideline. If you use an aggregated model instead of modelling individual units, you must demonstrate that the aggregated model accurately represents the characteristics of the entire facility at the connection point. To this end, you must provide any relevant underlying assumptions.

#### 4.2.1 Active power output of the generating unit/ station

The Asset Owner should conduct an FRT study at both 80%, and 100% of the maximum continuous output (MCO) of the generation. However, Inverter based generation is also expected to be studied at 20% of its MCO with all inverters are in service. Asset Owner can limit the EMT studies to two most onerous generation outputs.

The System Operator expects you to identify and study any power output conditions below maximum generation that may be onerous for FRT studies. A simple example of this would be a site with more than one connection to the grid, where, during an outage, the output through one or more of those connections may surpass its output under intact conditions, despite the total station output being lower.

If a facility has more than one operating mode, then you must study the FRT performance of the facility in all its configurations. For example, battery or hybrid connections must include import, export and idling modes.

#### 4.2.2 Reactive power output of the generating unit/station

You must identify the reactive power capability at the connection point for the expected grid voltage range. To demonstrate successful fault ride through, studies should include the expected operation as well as identify the most onerous pre-fault reactive power dispatch conditions for both lagging and leading power factors.

Further, for a synchronous generating station, you should carry out sensitivity studies to assess the performance of generating units when operating near their under-excitation and over-excitation limits.

All nearby generating stations should be dispatched to manage their respective target bus voltages within an acceptable operating range, typically between 1.0- 1.05 pu. Bus voltage profiles provided in Figure 3-1 (see section 3.3 above) serve as a starting point to configure the study cases. Fault ride through studies should include a voltage of 1.00 p.u. at the point of connection. You should also perform sensitivity studies at the most common voltage levels expected at the PCC to reflect the existing operating voltage range as shown in Figure 3-1, allowing for any impact of the new connection.

## 5 Other Generation

It is expected to study the sensitivity of maximum wind and 80% wind scenarios, for Grid Zone 6, 7 and 8 wind generation, for both peak and trough conditions.

Wind generation at Turitea, Tararua, Te Apiti and Waipipi are expected to have the largest influence on the region close to Bunnythorpe and at Te Kowhai for connections at or close to Taumarunui.

High HVDC flow scenarios (North and South) should also be studied, and sensitivity studies should also be included without Stratford generation.

It should be noted that dynamic models are not included for any IBR generation in this region. You may consult SO to check for the availability of these models at the time of the study.

The hydro units connected closely to Wairakei or Whakamaru (e.g. at Aratiati, Atiamuri, Whakamaru, Maraetai and Rangipo) are highly dispatchable and can be scaled as needed. If additional adjustments are required, wind generation outside the study area or DC flow can also be scaled.

## 6 Relevant External Conditions

The System Operator requires Asset Owners to ensure that permanent splits are enabled during the studies, particularly those relevant to this region. These are documented here: [Appendix A Grid Configuration Minor update 2025](#)

## 7 Fault Conditions

The studies to be documented are not simply the product of all the various faults, outages and system conditions identified in this document. The FRT study should identify and focus on the most difficult fault ride through conditions.

### 7.1 Fault types

The study can demonstrate fault ride through capability with three-phase balanced faults to ground and single-phase to ground faults with zero impedance. Further, it is necessary to study the line-line-ground fault for inverter based resources. To clear the fault, remove faulted circuits from the system after the designated fault clearance time mentioned in the next section (7.2).

FRT studies should also include failed auto-reclose scenarios. Auto-reclose is enabled by default on 220kV transmission lines and will re-close onto 3 phase faults. Default reclose times of 1 second should be applied.

Further, the System Operator suggests to detail the fault duration and retained voltage at the PCC as stipulated in section 4.6.4 in [GL-EA-953](#) to demonstrate fault ride through performance in compliance with Code clause 8.25A.

### 7.2 Fault clearance times

For the specific faults specified in Table 7-1 and Table 7-2 below, use the following durations:

- **220kV faults:** 120ms; while the close in end to a circuit fault is likely to clear earlier than 120ms, this is the currently designed guaranteed clearance time and should be applied at both ends.
- **110kV faults:** although target clearance time is 120ms for Zone 1, the EIPC Benchmark Agreement design fault clearance time allows 200ms for 110kV circuits. Therefore, 200ms fault clearance time should be used for the 110kV circuit faults.
- **33 kV faults:** fault clearance times can be assumed as up to 1000ms.

### 7.3 Fault locations

We have listed the faults to be studied under each 220kV and 110kV PCC groups in Table 7-1 and Table 7-2 respectively. Asset Owner remains responsible for identifying the onerous fault locations that result in an inability to ride through a system fault under each PCC group.

For 110kV or lower voltage connections within PCC groups E, F or G, you should also include the faults associated with the nearest 220kV bus (PCC group).

For example, if a new connection (BPE) belongs to PCC group A, you should study faults under PCC group A in

Table 7-1. However, for a new connection at 110kV bus in group F (MTR), you should study the faults under the PCC group A in

Table 7-1 in addition to faults under PCC group F in Table 7-2.

**Table 7-1: Fault cases to be studied under each 220kV PCC groups; A, B, C and D**

PCC Group A	PCC Group B	PCC Group C	PCC Group D
BPE-HAY-PRM circuit 2	BPE-TNG circuit 1	BPE-TKU circuit 2	SFD-TMN circuit 1
BPE-LTN circuit 2	TNG-RPO circuit 1	TKU-WKM circuit 2*	TMN-TWH circuit 1
BPE-TKU circuit 2	RPO-WRK circuit 1	BPE-TNG circuit 1	HLY-SFD circuit 1
BPE-TNG circuit 1	WKM-WRK circuit 2	BHL-PAK-WKM circuit 2	HLY-TWH circuit 1
BPE-BRK circuit 2	BPE-TKU circuit 1		BRK-SFD circuit 1
HAY-LTN-WIL circuit 2	BPE-BRK circuit 2		
TKU-WKM circuit 2*			
TNG-RPO circuit 1			
BPE T3			

\* Note that there is a Special Protection Scheme associated with the tripping of this circuit irrespective of any overloading.

**Table 7-2: Fault cases to be studied under each 110kV PCC groups; E, F and G**

PCC Group E	PCC Group F	PCC Group G
BPE-MHO circuit 2	BPE-MTR circuit 1	BPE-WDV circuit 2
BPE-MTN-WGN circuit 2	MTR-OKN circuit 1	DVK-WPW circuit 2
WGN-WVY circuit 1	OKN-NPK-ONG circuit 1	BPE-MTR circuit 1
BPE-WDV circuit 1	ARI-HTI-ONG circuit 1*	DVK-WDV circuit 2
WVY-HWA circuit 1	BPE-WDV circuit 2	BPE T3
BPE T3	BPE T3	
SFD T10		

For all PCC groups, a trip of the HVDC bipole should be tested such that the results demonstrate the asset's compliance to Electricity Industry Participation Code 2010, Part 8, Clause 8.25A(2).

The assessment should also simulate faults with the outages defined in section 3.4 to confirm the FRT performance during outage conditions.

You should select fault locations on the circuits, at both ends of the circuit, not at intermediate points.

The System Operator expects you to specify islanding protection separately; no islanding analysis is expected in these studies.

### 7.3.1 EMT studies

EMT studies should be a subset of the RMS studies carried out. The selection of fault cases should include the most onerous cases identified in the RMS studies and be sufficiently comprehensive to demonstrate the expected FRT capability.

If EMT results show significant differences to RMT results, the scope of EMT studies should be expanded to provide sufficient evidence that the required FRT performance will be achieved.

## 7.4 Over-voltage simulations

Over-voltage situations are relatively unusual for the Bunnythorpe region under normal system operations. These are typically associated with the unexpected loss of significant load or the HVDC bipole trip at high power transfer. Over-voltage ride through could be studied by either simulating load shedding within the Bunnythorpe region or simulating a bipole trip at high DC transfer. In either case an over voltage event without an associated frequency event is usually acceptable for the FRT study, please discuss these studies with the System Operator if necessary. We recommend that you simulate an over-voltage scenario using a summer trough case.

## Appendix: Site Codes

Abbreviation	Full Name
BPE	Bunnythorpe
LTN	Linton
TKU	Tokaanu
RPO	Rangipo
TNG	Tangiwai
TMN	Taumarunui
WGN	Wanganui
MTN	Marton
MHO	Mangahao
WDV	Woodville
DVK	Dannevirke
WPW	Waipawa
MTR	Mataroa
OKN	Ohakune
NPK	National Park
TWC	Tararua 3
TUR	Turitea
TAP	Te Apiti

