



TRANSPOWER

# Modelling Requirements for Inverter-based Resources

GL-EA-1311

TP Ref: GL-EA-1311

Status: Issued

Approval Date: 26/06/2026





| Version | Date         | Change   |
|---------|--------------|--|
| 1.0     | 26 June 2026 | First issue; split modelling requirements between this document (IBR) and GL-EA-716 (synchronous); guidance aligned with CACTIS requirements |
|         |              |  |
|         |              |  |

|              | Name & Position                      |
|--------------|--------------------------------------|
| Prepared By: | Senior Engineer, Power Systems Group |
| Reviewed By: | Nyuk-Min Vong                        |
| Approved By: | Engineering Assurance Manager        |

**IMPORTANT**

**Disclaimer**

The information in this document is provided in good-faith and represents the opinion of Transpower New Zealand Limited, as the system operator, at the date of publication. Transpower New Zealand Limited does not make any representations, warranties or undertakings either express or implied, about the accuracy or the completeness of the information provided. The act of making the information available does not constitute any representation, warranty or undertaking, either express or implied. This document does not and is not intended to; create any legal obligation or duty on Transpower New Zealand Limited. To the extent permitted by law, no liability (whether in negligence or other tort, by contract, under statute or in equity) is accepted by Transpower New Zealand Limited by reason of, or in connection with, any statement made in this document or by any actual or purported reliance on it by any party. Transpower New Zealand Limited reserves all rights, in its absolute discretion, to alter any of the information provided in this document.

**Copyright**

The concepts and information contained in this document are the property of Transpower New Zealand Limited. Reproduction of this document in whole or in part without the written permission of Transpower New Zealand is prohibited.

**Contact Details**

**Address:** Transpower New Zealand Ltd  
 Waikoukou - 22 Boulcott St  
 PO Box 1021  
 Wellington  
 New Zealand

**Telephone:** +64 4 590 7000

**Email:** [system.operator@transpower.co.nz](mailto:system.operator@transpower.co.nz)

**Website:** <http://www.transpower.co.nz>



# Table of Contents

- Introduction ..... 4**
- 1 Abbreviations..... 6**
- 2 Scope..... 7**
  - 2.1 Requirements at a Glance .....7
  - 2.2 Intended Use of Models.....8
- 3 Software Specifications ..... 9**
  - 3.1 Software Packages and Versions .....9
  - 3.2 File Structures.....9
  - 3.3 File Names..... 12
  - 3.4 User Guide and Version Control ..... 12
- 4 Model Quality ..... 14**
  - 4.1 Model Encryption ..... 14
  - 4.2 Root Mean Square (RMS) Model..... 15
  - 4.3 Electromagnetic Transient (EMT) Model ..... 17
  - 4.4 Representation of Physical Components ..... 19
  - 4.5 Dynamic Reactive Power Compensation Devices..... 23
- 5 Testing ..... 25**
  - 5.1 Testing Parameter Integrity ..... 25
  - 5.2 Measurement Points ..... 25
  - 5.3 Commissioning and Routine Testing..... 26
  - 5.4 Validation against Test Data ..... 26
  - 5.5 M2 Model Parameter Integrity..... 27
  - 5.6 Network Model Integration..... 27
  - 5.7 Validation Report..... 28
- 6 Benchmarking ..... 29**
  - 6.1 Benchmarking Test Setups..... 29
  - 6.2 Benchmarking Tests..... 30
- Appendix A. Model Submission Checklist ..... 34**
- Appendix B. Validation Report Template..... 35**
- Appendix C. Process for RMS Model Submission ..... 37**
- Appendix D. Process for EMT Model Submission..... 38**
- Appendix E. Impedance Requirements ..... 39**
  - E.1 Grid-connected IBR Stations ..... 39
  - E.2 Embedded IBR Stations..... 39
- Appendix F. Model Acceptance Criteria..... 41**
  - F.1 Steady-State Response (No Disturbance)..... 41
  - F.2 Transient Response: Step Change Test and Benchmarking..... 41
  - F.3 Small Signal Response: Oscillation Assessment ..... 42
  - F.4 Small Signal Response - Benchmarking Tests..... 43
  - F.5 Model Validation Against Measured Response ..... 43
- Appendix G. Model Requirement Template (AO-OEM)..... 44**
  - G.1 Accepted Software Version..... 44
  - G.2 Model Details ..... 44
- 7 Document Information ..... 45**
  - 7.1 Metadata..... 45

# 1 Introduction

This document guides you, the asset owner, to understand the requirements for developing mathematical models of power system equipment. Following our guidance will mean your models are fit-for-purpose and can be appropriately validated. The System Operator requires that you submit these, alongside with supporting information so that we can plan to meet, and meet, our principal performance obligations (PPOs).



This guide focuses on **inverter-based resources**: wind, solar/photovoltaic (PV), battery energy storage systems (BESS), dynamic reactive power compensation devices, and doubly-fed induction generators (DFIG). We recommend owners of DFIG seek System Operator advice in regards to their particular setup.

If you want to model a synchronous asset, refer to our [GL-EA-716](#) guideline.

If you are commissioning an asset, this guide forms part of a suite of documents that support you in that process. Refer to the document suite on the next page for hyperlinks to the other documents and for an idea of when you should consult them. In particular, we expect you to read this document alongside the following:

- the [Electricity Industry Participation Code 2010](#) (the Code), especially Part 8, which includes the most up-to-date performance requirements
- the [Connected Asset Commissioning, Testing, and Information Standard](#) (CACTIS), especially Chapter 4
- [GL-EA-953](#) Connection Study Requirements
- [GL-EA-010](#) Generator Testing Requirements

Providing mathematical models is a requirement of the Code. This document expands on the requirements stipulated in Part 8 of the Code and Chapter 4 of the [CACTIS](#). The information provided seeks to answer common questions about modelling software, supporting documentation, and validation. We recommend you familiarise yourself with both your requirements and our guidance to avoid costly and time-consuming rework and potential delays.

*Note: Model validation remains the responsibility of asset owners, as does compliance with all your obligations as stipulated in the Code (and any incorporated documents, such as the CACTIS). You therefore need to read, understand, and comply with asset owner obligations outlined within the Code. If there is a conflict between this document and the Code, the Code takes precedence. If you engage a consultant for testing and model validation purposes, you should share all relevant documentation with them so they are aware of our requirements.*

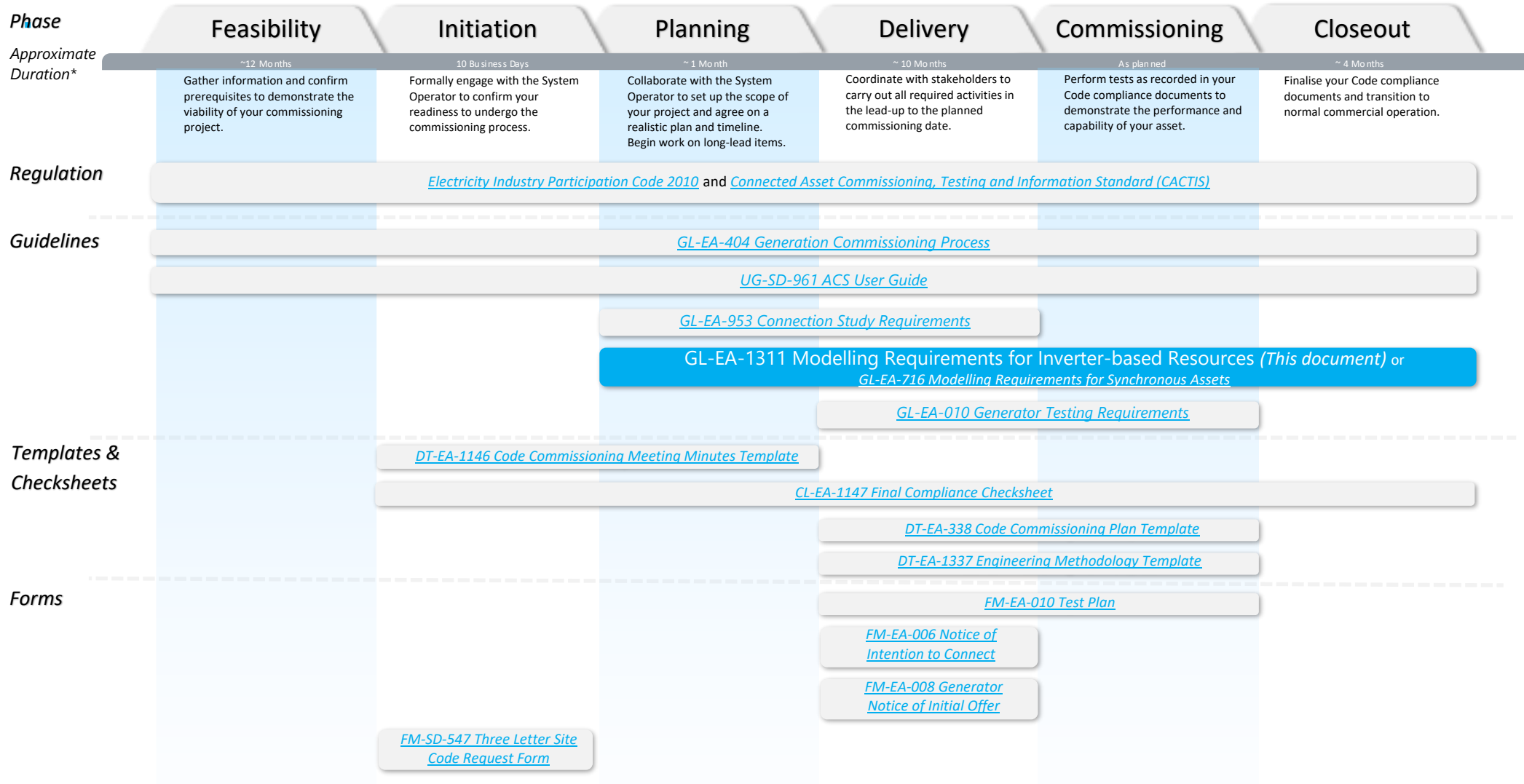

\* Consult CACTIS for mandated time frames

Figure 1 - Supporting Documentation Suite



## 2 Abbreviations

| Abbreviation    | Full Form/Explanation  |
|-----------------|--|
| <b>AC</b>       | Alternating Current  |
| <b>ACS</b>      | Asset Capability Statement   |
| <b>AVR</b>      | Automatic Voltage Regulator  |
| <b>BESS</b>     | Battery Energy Storage System  |
| <b>DC</b>       | Direct Current   |
| <b>DFIG</b>     | Doubly-Fed Induction Generators  |
| <b>DLL</b>      | Dynamically Linked Library   |
| <b>DSA</b>      | Dynamic Security Assessment  |
| <b>DSL</b>      | Dynamic Simulation Language (PowerFactory software)  |
| <b>EMT</b>      | Electromagnetic Transient  |
| <b>ESCR</b>     | Effective Short Circuit Ratio  |
| <b>FRT</b>      | Fault Ride Through   |
| <b>GFL</b>      | Grid Following (inverter)  |
| <b>GFM</b>      | Grid Forming (inverter)  |
| <b>IBR</b>      | Inverter Based Resource (generation)   |
| <b>IEEE</b>     | The Institute of Electrical and Electronics Engineers  |
| <b>IP</b>       | Intellectual Property  |
| <b>MSC</b>      | Mechanically switched capacitors   |
| <b>MSR</b>      | Mechanically switched reactors   |
| <b>NDA</b>      | Non-Disclosure Agreement   |
| <b>NERC</b>     | North American Electric Reliability Corporation  |
| <b>NREL</b>     | National Renewable Energy Laboratory (USA)   |
| <b>OEM</b>      | Original Equipment Manufacturer  |
| <b>OLTC</b>     | On Load Tap Changer (Transformer)  |
| <b>POC</b>      | Point Of Connection (POC)/ Point of Common Coupling (PCC)  |
| <b>PLL</b>      | Phase-Locked Loop  |
| <b>PSCAD</b>    | Power Systems Computer Aided Design<br>Software package used to conduct EMT-type studies           |
| <b>PSS</b>      | Power System Stabilizer  |
| <b>PSS/E</b>    | Power System Simulator for Engineering<br>Software package used to conduct RMS-type studies        |
| <b>PV</b>       | Photovoltaic   |
| <b>RMS</b>      | Root Mean Square   |
| <b>SPP</b>      | Solar Power Plant  |
| <b>STATCOM</b>  | Static Synchronous Compensator   |
| <b>SVC</b>      | Static VAR Compensator   |
| <b>The Code</b> | Electricity Industry Participation Code 2010   |
| <b>TSAT</b>     | Transient Security Assessment Tool<br>Software package used to conduct real-time frequency studies |
| <b>UDM</b>      | User Defined Model   |
| <b>WECC</b>     | The Western Electricity Coordinating Council   |
| <b>WPP</b>      | Wind Power Plant   |
| <b>WTG</b>      | Wind Turbine Generator   |

## 3 Scope

The purpose of this guideline is to support asset owners to accurately represent the performance of their inverter-based resources, including wind- and solar/photovoltaic (PV)-powered plants, BESS, dynamic reactive power compensation devices, and doubly-fed induction generators (DFIG).



Refer to chapter 4 of the [CACTIS](#) for mandated requirements. The guidance in this document primarily applies to the creation of M2 models, as defined in the CACTIS. Where a requirement outlined in this guideline cannot reasonably be demonstrated prior to commissioning, it shall apply only to the M2 model unless otherwise stated.

### 3.1 Requirements at a Glance

Asset owners can use this section to familiarise themselves with the high-level modelling requirements. We also have a requirements template in Appendix G to share with OEMs to support the provision of the required information.

#### 3.1.1 M1 Model (Connection Study Model)

- An M1 model must be provided to support connection studies.
- The M1 model must represent the IBR asset with all site specific electrical and control parameters, and shall reflect the intended operating configuration control modes at the time of connection.
- The M1 model must include, as a minimum:
  - an IBR model representing the inverter electrical characteristics, interface transformer(s), and connection arrangement;
  - a representation of the voltage and reactive power control system, including plant-level and inverter-level controls, and any supplementary limiters or control functions relevant to voltage performance;
  - a representation of the frequency and active power control system, configured to reflect the intended operating mode(s) (e.g. droop-based response, fast frequency response, power reference control);
  - include explicit representation of grid-following (PLL-based) and/or grid-forming (voltage-source-based) control behaviour consistent with the intended operating mode;
  - where applicable, a representation of the Power Oscillation Dampers (POD), fault ride through algorithm, grid-forming control functions, virtual inertia or equivalent fast frequency response features consistent with the intended in-service configuration; and
  - a representation of protection and current-limiting functions with appropriate preliminary settings.
- The M1 model is intended to demonstrate the expected dynamic behaviour of the IBR for the purposes of connection assessment and system studies.
- The M1 model needs to be submitted in accordance with the applicable time frame in chapter 1 of the CACTIS.

#### 3.1.2 M2 Model (Final Validated Model)

- An M2 model must be provided as the final validated model for the IBR following commissioning and testing.
- The M2 model must include:
  - the inverter and plant electrical model with final as-built parameters;
  - a detailed representation of the voltage and reactive power control system, including all limiters, supplementary controls, and as-left parameter settings;

- a detailed representation of the active power and frequency control system, configured with as-left settings, including all intended operating and response modes;
  - where applicable, a representation of the Power Oscillation Dampers (POD), grid-forming control functions, virtual inertia or equivalent fast frequency response features consistent with final in-service configuration; and
  - a representation of protection and current-limiting functions with appropriate as-left settings.
- The M2 model (Power factory and PSCAD) must be validated against commissioning test results and shall be suitable for use in operational, planning, and dynamic stability studies undertaken by the System Operator. The TSAT M2 model must be benchmarked against validated PSCAD model.
- The M2 model must be submitted in accordance with the mandated time frames (in chapter 1 of the CACTIS) following completion of commissioning and validation activities.

## 3.2 Intended Use of Models

The System Operator uses models to conduct accurate load-flow analysis, dynamic stability assessments and other system studies. Models are used at appropriate stages of the commissioning process and throughout the operational life of a the asset.

The accuracy of these assessments helps us to :

- demonstrate Code compliance for power system conditions that cannot be readily replicated during on-site testing;
- assess the steady-state and dynamic performance of the power system, including the determination of operating and stability limits that define the boundaries of secure operation;
- support efficient system operation and dispatch of offered;
- perform studies to ascertain the frequency capabilities of equipment, including the reserve assessments (where offered) and incident investigations;
- perform system frequency response and voltage stability studies in the context of contingent and extended contingent events.

## 4 Software Specifications

### 4.1 Software Packages and Versions

You must submit models using the following software formats:

- DigSILENT's **PowerFactory V2024**
- PowerTech's **Transient Security Assessment Tool (TSAT) V24**
- **Power System Computer Aided Design (PSCAD) V5.02**
  - For PSCAD models, **Intel Fortran Classic 2021.12.0** 32bit and 64bit compiler

The System Operator maintains and updates the approved software to the versions referenced above. Before submitting models, we recommend confirming the latest accepted software versions with us.

The above software versions will allow you to utilise up-to-date PowerFactory case files of the New Zealand power system that the Electricity Authority [makes available for system studies](#). For EMT studies you can utilise the EMT zonal model provided on [Power System Studies and Modelling](#) webpage.

The RMS and EMT models of your asset must be submitted in accordance with Appendix C and Appendix D respectively.

*Note: If your original equipment manufacturer (OEM) deems that their PowerFactory model is confidential and therefore not shareable, then you must **additionally** provide the System Operator with a generic RMS stability model. We will accept such a generic model provided that it fulfils the following criteria:*

- *The model is prepared as per WECC generic model specifications.*
- *The model can represent the dynamic behaviour of the IBR with sufficient accuracy.*

### 4.2 File Structures

#### 4.2.1 PowerFactory

To facilitate your model's integration into System Operator model cases, use the study case and library structures and naming conventions in Table 1. For further guidance, refer to the example PowerFactory model and accompanying readme file on our [Power System Studies and Modelling](#) webpage.

You should also:

- organise your models into the appropriate folders named after the equipment type they belong in. For instance, store AVR and voltage control system models in a "voltage control system" folder. Place the models in the standard "Equipment Type Library" folder;
- store the user macros of each component in the individual component library pack (pack macros);
- store the Element.dsl in the relevant component library with the as-left controller parameters; and
- provide the model in a ready-to-run validation case or project. As part of the initial checks of your submission, the System Operator must be able to activate the project and easily replicate all test results and graphs included in the model validation report.

Table 1: Study Case and Library Structures for Submitting DlgSILENT PowerFactory Models

| Study Case Structure   | Library Structure  |
|--|--|
| <ul style="list-style-type: none"> <li>▼ Study Cases                             <ul style="list-style-type: none"> <li>&gt; Active Power / Frequency Response Tests</li> <li>&gt; Reactive Power Step Tests</li> <li>&gt; Small Voltage Disturbance Tests</li> <li>&gt; Voltage Step Tests</li> </ul> </li> <li>▼ Network Variations (0, 0 active)                             <ul style="list-style-type: none"> <li>☐ (no active Expansion Stage)</li> <li>&gt; ☐ Test 5.1 49.5 Hz</li> <li>&gt; ☐ Test 5.1 49.9 Hz</li> <li>&gt; ☐ Test 5.1 50.1 Hz</li> <li>&gt; ☐ Test 5.1 50.5 Hz</li> <li>&gt; ☐ Test 5.2 OLTC step down</li> <li>&gt; ☐ Test 5.2 OLTC step up</li> <li>&gt; ☐ Test 5.3 Voltage step neg</li> <li>&gt; ☐ Test 5.3 Voltage step pos</li> <li>&gt; ☐ Test 5.4 Reactive step</li> <li>&gt; ☐ Test 5.5 OLTC step down</li> <li>&gt; ☐ Test 5.5 OLTC step up</li> <li>&gt; ☐ Test 5.6 Voltage step neg</li> <li>&gt; ☐ Test 5.6 Voltage step pos</li> </ul> </li> </ul> | <ul style="list-style-type: none"> <li>▼ Library                             <ul style="list-style-type: none"> <li>&gt; Library</li> <li>&gt; Operational Library</li> <li>&gt; Scripts</li> <li>▼ Templates                                     <ul style="list-style-type: none"> <li>&gt; Wind33</li> <li>&gt; DRIG-33kV</li> <li>&gt; TAPwind110Enc</li> <li>▼ WPP   <ul style="list-style-type: none"> <li>&gt; WPP</li> <li>▼ Library   <ul style="list-style-type: none"> <li>▼ WPP   <ul style="list-style-type: none"> <li>▼ IEC61400-27-1 (2015)   <ul style="list-style-type: none"> <li>☐ Constant Q limitation model</li> <li>☐ Current limitation model</li> <li>☐ Grid Protection Model</li> <li>☐ P control model type 4B</li> <li>☐ Q control model</li> <li>☐ QP and QU limitation model</li> <li>☐ Reference frame rotation model (PLL)</li> <li>☐ Two mass model (Type 3)</li> <li>☐ Type 4 generator set model</li> <li>☐ Type 4B Frame</li> </ul> </li> </ul> </li> </ul> </li> </ul> </li> </ul> </li> </ul> </li> </ul> |

### 4.2.2 TSAT

Use the study case and library structures and naming conventions in Table 2 below to help you organise your TSAT models.

Table 2: Study Case and Library Structures for Submitting PowerTech TSAT Models

Study Case Structure

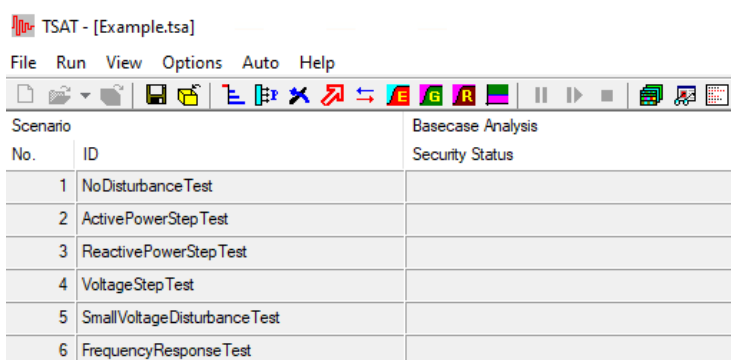

| Scenario |                             | Basecase Analysis |
|----------|-----------------------------|-------------------|
| No.      | ID                          | Security Status   |
| 1        | NoDisturbanceTest           |                   |
| 2        | ActivePowerStepTest         |                   |
| 3        | ReactivePowerStepTest       |                   |
| 4        | VoltageStepTest             |                   |
| 5        | SmallVoltageDisturbanceTest |                   |
| 6        | FrequencyResponseTest       |                   |

Library Structure

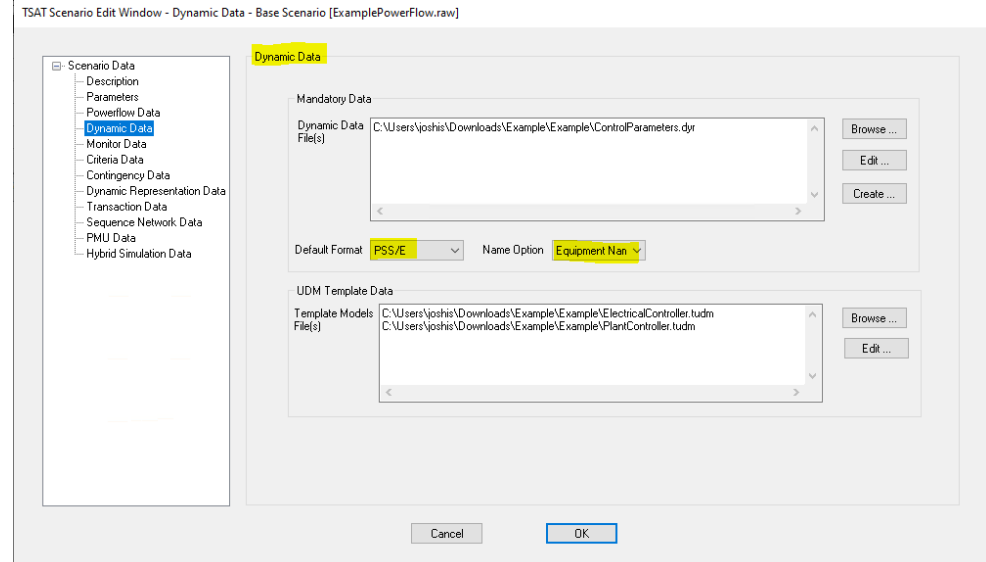

TSAT Scenario Edit Window - Dynamic Data - Base Scenario [ExamplePowerFlow.raw]

**Dynamic Data**

Mandatory Data

Dynamic Data File(s):  Browse ...

Edit ...

Create ...

Default Format: PSS/E Name Option: Equipment Nan

UDM Template Data

Template Models File(s):  Browse ...

Edit ...

Cancel
OK

You should also:

- ensure that the TSAT user-defined model (UDM) is compatible with the equipment name format;
- ensure that the UDM canvas is not password-protected; and
- ensure that the UDM accepts spaces in generator equipment name.

### 4.2.3 PSCAD

- Use the study case and library structures and naming conventions in below to help you organise your PSCAD models.

Table 3: Study Case and Library Structures for Submitting PSCAD Models

Study Case Structure

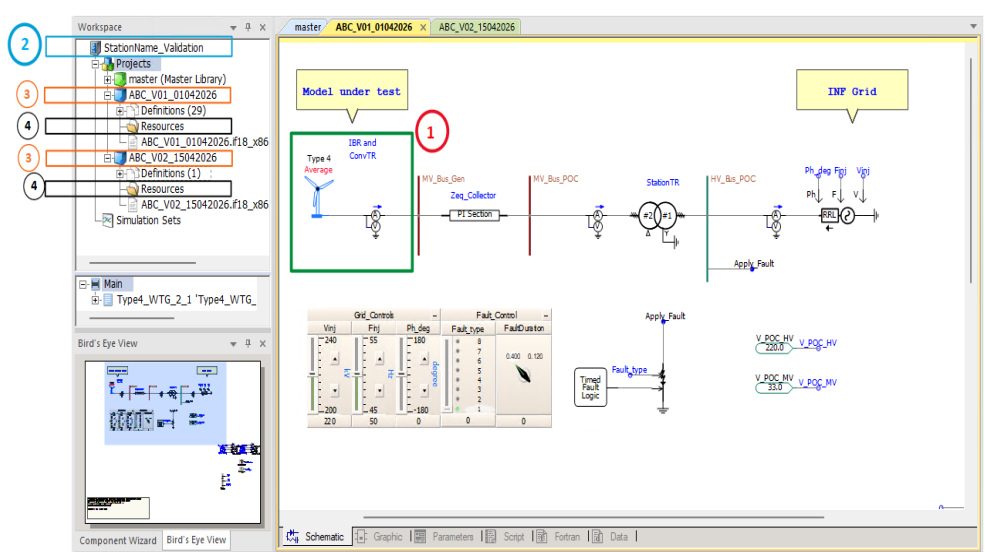

Name the workspace and file name as outlined below:

|   |                 |  |
|---|-----------------|--|
| 1 | Model placement | Replace the model with the model of your asset   |
| 2 | Workspace name  | (Station name)_Validation  |
| 3 | Project name    | <b>ABC</b> (Station 3 digit code)_ <b>V01</b> (Version of model)_20260601 (validation date yyyymmdd) |
| 4 | Resources       | Library files / Measurement files / Scripts  |

Library Structure

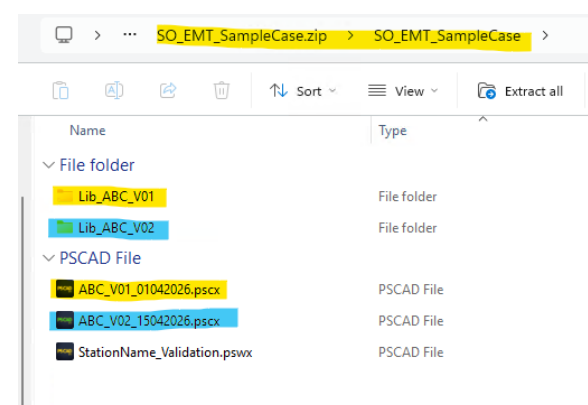

You should also place the library files in respective folder named as:  
**Lib\_ABC**(Station 3 digit code)\_**V01**(Version of model)

### 4.3 File Names

When submitting models or combined .zip files via ACS or any data-sharing platform, ensure that your files utilise the following standard naming convention:

**M1 model : ABC\_M1 model\_Vx\_YYYYMMDD**

**M2 model : ABC\_M2 model\_Vx\_YYYYMMDD**

Where:

- ABC = Station three-letter code
- Vx = Version number (e.g. V1, V2.1)
- YYYYMMDD = Submission date

### 4.4 User Guide and Version Control

Models must be accompanied by user guide documentation containing all the information required to use the model as part of system studies without needing to have any prior knowledge of the equipment, content of validation package, or validation techniques in question. You can have either provide a separate guide document for each software package, or you can combine them into one document with separate sections. The guide should include:

- block diagrams showing all control system components and how they are interlinked;
- a complete parameter list with definitions and impact on model behaviour;
- clear instructions for the System Operator to replicate model setup, including external dependencies;
- a description of the calculation methods, control logic, or design assumptions used to derive or configure key IBR parameters and functions, such as fast frequency response, active and reactive power control modes, fault ride-through (FRT) behaviour, current limiting strategies, and any grid following (GFL) or grid forming (GFM) control features;
- known limitations of the model during initialisation, normal operation or abnormal operation of asset;
- a description of secondary or station control system able to act within 5 minutes to change the active or reactive power output;
- details of any OEM specific UDM or control block diagrams that the System Operator could use to rebuild the models in other software (if needed);
- a clear description of any aggregation methodology applied to represent multiple inverters, feeders, transformers, or plant sections as an equivalent model, including the rationale for aggregation;
- if applicable, the benchmarking report undertaken between the RMS/phasor-domain model and the corresponding validated EMT model, including the scope, objectives, and limitations;
- details of any model encryption or simplification, including associated assumptions and limitations; and
- where a generic WECC models is provided, a description of the derivation methodology (e.g. curve-fitting or response matching), including source data, assumptions, and limitations.

*Note: When submitting an unencrypted M2 model, ensure your user guide includes sufficient information to enable integration into the System Operator's PowerFactory environment.*

To ensure traceability and consistency between submitted models, the user guide must also include version control information, including:

- software version used to develop the model;
- model version number and author;



- date of last modification;
- data or information sources;
- a discrete list of changes since the previous version;
- compiler version (where applicable, typically for PSCAD models); and
- versioning of individual model components where supported by the software.

## 5 Model Quality

### 5.1 Model Encryption

#### 5.1.1 PowerFactory Model

Submitted **M1** PowerFactory models may be **encrypted**, while **M2** PowerFactory models must be **unencrypted**. This allows the System Operator to:

- fully access, review, and understand the internal structure and behaviour of the model;
- understand the control logic and mathematical implementation;
- access and modify all signals, equations, and initial conditions;
- use the model for operational and planning studies over the life of the asset (only applicable to M2 models); and
- validate model performance and investigate asset compliance following system disturbances (only applicable to M2 models).

Models must be developed in accordance with the model format requirements specified in Section 5.1.3 below.

#### 5.1.2 TSAT and PSCAD Models

Submitted TSAT and PSCAD models may be **encrypted**, provided that the encryption does not prevent the System Operator from accessing the minimum information required to assess model behaviour and performance.

At a minimum, your models must meet the following requirements:

- The System Operator has access to the following signals:
  - $V_d$ ,  $V_q$ ;
  - $I_d$ ,  $I_q$ ;
  - measured or calculated PLL frequency ( $F_{pll}$ ); and
  - all trip and protection status flags, including FRT flags at both the plant controller (PPC) and individual unit/inverter level (where applicable).
- Tap-changer control logic, switchable shunt control logic and timing parameters are provided in an editable format for fast initialisation.
- Model parameter names and parameter values are **not** encrypted.
- Encryption does not prevent the System Operator from:
  - accessing and modifying all signals;
  - understanding protection actions; and
  - validating model response under disturbance and steady-state conditions (applicable to M2 models).
- The model is developed in accordance with the model format requirements specified in Section 5.1.3 below.

#### 5.1.3 Model Development Formats

The model can be developed and submitted in one of the following formats:

### 5.1.3.1 Model Block Diagram Format

In this format, the model is constructed using basic control blocks with a graphical representation of the control system components. This format requires that:

- all control blocks, logic, mathematical equations, signal flows, and programming code are visible and accessible to the System Operator;
- no parts of the model are hidden, locked, or compiled in a manner that prevents inspection or modification; and
- the internal structure of excitation systems, governors, limiters, and supplementary controls can be reviewed and validated.

### 5.1.3.2 Model Source Code Format

In this format, the model is provided in a form that enables the control system functions to be implemented using written and organised programming logic that is accessible to the System Operator within the relevant simulation tool. The implementation may be provided using tool-specific mechanisms, including compiled libraries, subject to the encryption and accessibility requirements specified in Sections 5.1.1 and 5.1.2.

The model source code format must satisfy the following criteria depending on the software platform:

|                       |  |
|-----------------------|--|
| <b>PowerFactory</b>   | The control logic and mathematical implementation must be readable and interrogable within PowerFactory, allowing the System Operator to inspect, trace, and understand signals, parameters, and control actions, and be provided without encryption or obfuscation that would restrict such access. |
| <b>TSAT and PSCAD</b> | The control system implementation may be provided in compiled or encrypted library form, provided the model exposes clearly defined inputs, outputs, parameters, and documented behaviour sufficient for validation, testing, and operational studies.   |

*Note: PSCAD models must be developed in full three-phase (ABC) representation, without positive-sequence or reduced-order approximations, and must incorporate sufficient control system detail to accurately capture asymmetrical faults, converter control dynamics and fast electromagnetic transients across the relevant frequency range.*

Refer to our [Power System Studies and Modelling](#) page for information about how we manage confidential models.

## 5.2 Root Mean Square (RMS) Model

### 5.2.1 RMS Model Component

An IBR generating station must be modelled as a full generating station in the RMS domain.

As a minimum, the RMS model must include:

- individual inverter units or an aggregated inverter representation, modelling the inverter electrical characteristics and control behaviour;
- generating unit and/or collector system transformers and relevant network interfaces;
- generating station auxiliary loads, where these materially affect station behaviour;
- the control systems for each inverter or plant-level controller, including active power, reactive power/voltage control, frequency response functions (including fast frequency response or equivalent), grid-forming or grid-following control functions (as applicable), and associated limiters; and

- any control, protection, or interlocking functions capable of reducing output or disconnecting the inverter unit(s) or generating station within a simulation timeframe of up to 60 seconds.

As a minimum, the model must include all relevant physical components, control systems, protection functions, limits, and mode-dependent logic as specified in Section 5.4.

In addition, the RMS model must:

- represent all intended operating modes within the active power, reactive power, voltage, and frequency control systems, including the ability to transition between modes and accept external control signals for use in real-time operation;
- use signals as inputs and outputs of DSL models for simulation (e.g. use a model signal such as 'ut' instead of a network measurement value such as 'u:bus1' for a machine terminal voltage, and use the provided measurement device models to provide network quantities as signals);
- not contain any unused, inactive, or redundant control blocks or program code.

### 5.2.2 RMS Model Initialisation

Models submitted to the System Operator must initialise correctly from load-flow solutions within the normal operating envelope of the equipment.

To ensure successful model initialisation, the RMS model must:

- initialise without run-time errors or run-time warnings related to incorrect or incomplete model initialisation;
- initialise successfully across the full operating range of active and reactive power;
- initialise successfully across the allowable voltage range at the point of connection; and
- use numerical integration time steps appropriate to the model, and should be **5 ms** or greater.

▪ *Note: If initialisation problems occur, you must resolve these before validating the model. Submitted models with unresolved initialisation problems will fail the System Operator's verification.*

You must demonstrate successful initialisation through a no-disturbance simulation of at least **120 seconds**, during which the model must remain within the limits specified in Table 4.

*Table 4: Acceptable range of simulated response*

| Quantity              | Acceptable range                          |
|-----------------------|---|
| Generator MW and MVAR | Within $\pm 1\%$ of MW and MVAR setpoint  |
| Controlled voltages   | Within $\pm 0.005$ pu of Voltage setpoint |

### 5.2.3 RMS Model Dynamic Performance

Models submitted to the System Operator must demonstrate adequate numerical performance and reliability across a representative range of operating and system conditions.

The model must be numerically stable for:

- a suitable range of ESCR and fault-level X/R ratios at the point of connection;
- operation across the intended active and reactive power operating envelope, including leading, lagging, and unity power factor operation, when network circuits closest to the point of connection are subjected to balanced and unbalanced faults;
- step changes to:

- voltage, reactive power, or power-factor set-points of the voltage/reactive power control system;
- frequency, active power, or power reference set-points of the active power/ frequency control system;
- system faults that are cleared by normal protection relay operation.

To demonstrate adequacy, simulations must include, where applicable:

- defined step changes to controller set-point references or inputs;
- defined signal injections to controller inputs;
- switching of static reactive devices;
- load rejection events;
- operation at maximum and minimum transformer tap positions; and
- correct application of rate-of-change limits (both positive and negative) where these are implemented in plant controls.

During testing and simulation, you must record sufficient data to enable meaningful comparison between simulation results and commissioning or test data, where such data is available.

Demonstrate model performance and reliability by running dynamic simulations of at least 60 seconds' duration, sufficient to identify any numerical issues, with reference to:

- active power;
- reactive power;
- voltage; and
- frequency.

## 5.3 Electromagnetic Transient (EMT) Model

### 5.3.1 EMT Model Components

The EMT model must represent the instantaneous electrical and control behaviour of the plant with sufficient fidelity to assess large-disturbance response, converter control behaviour, protection operation, mode switching, non-linear limiting behaviour, and interaction with the connected network under balanced and unbalanced disturbances.

As a minimum, the model must include all relevant physical components, control systems, protection functions, limits, and mode-dependent logic as specified in Section 5.4.

### 5.3.2 EMT Model Initialisation

EMT models submitted to the System Operator must initialise correctly from load-flow solutions across the normal operating range of the asset.

To ensure successful model initialisation, the EMT model must:

- initialise without run-time errors or warnings related to incorrect or incomplete model initialisation;
- initialise successfully across the full active and reactive power operating range;
- initialise successfully across the allowable voltage range at the point of connection;
- use numerical integration time step of **10µS** or greater;
- initialise within **3 seconds** of the start of a simulation and support snapshot capability; and
- be compiled using both 32-bit **and** 64-bit Intel Fortran compiler.

Demonstrate successful initialisation through a no-disturbance simulation of at least **30 seconds**, during which the model remains within the limits specified in Table 4 above.

### 5.3.3 EMT Model Dynamic Performance – Large Disturbance

EMT models submitted must demonstrate robust numerical performance and reliable dynamic behaviour when subjected to large disturbances. The model must:

- correctly represent converter current limiting, active/reactive current allocation, limit recovery, and associated non-linear control behaviour;
- demonstrate stable and physically-realistic PLL behaviour across a representative range of ESCR values and fault-level X/R ratios at the point of connection;
- correctly represent:
  - balanced and unbalanced fault ride-through behaviour and post-fault recovery for faults cleared by normal protection operation;
  - plant response to step changes in voltage, reactive power, power factor, frequency, active power, and active power reference, as applicable; and
  - implemented rate limits, mode switching behaviour, and protection or control function activation under stressed conditions;
- produce responses that are technically consistent with the modelled control structure, implemented settings, and expected plant behaviour;
- avoid numerical artefacts related to discretisation, saturation, or control wind-up;
- exhibit appropriate separation of control bandwidths between inner, outer, and plant-level controls to avoid control interactions.

### 5.3.4 EMT Model Dynamic Performance – Small Disturbance

The EMT model must be capable of reproducing small-signal and control interaction behaviour when subjected to small disturbances around relevant steady-state operating points. The model must:

- accurately represent small-signal and control-interaction dynamics, including oscillatory behaviour in both synchronous and sub-synchronous frequency ranges;
- support frequency-domain or dq-frame interrogation (e.g. impedance or admittance scanning) such that plant behaviour can be characterised at relevant operating points;
- produce impedance or frequency-response characteristics that are consistent with the underlying control system behaviour and suitable for use in small-signal or eigenvalue-based analysis;
- demonstrate robustness under reduced system strength conditions, including behaviour approaching instability;
- produce responses consistent with derived small-signal (eigenvalue) and/or impedance-based assessments; and
- enable identification of adverse control interaction, insufficient damping, or instability arising from interaction between plant control systems and network dynamics, particularly under weak-grid conditions.

Where impedance or frequency-domain representations are derived from the EMT model, ensure that sufficient detail and access is provided to the System Operator to enable independent verification of the derived characteristics.

### 5.3.5 Simulation Coverage and Performance Demonstration

The adequacy of the EMT model must be demonstrated through dynamic simulations covering the full intended operating range and representative system conditions. Such assessments must include:

- operation across the full active and reactive power range, including leading, lagging, and unity power factor conditions;
- response to both large disturbances (e.g. faults) and small disturbances (e.g. set-point changes or perturbations);
- defined step changes to controller set-points or reference inputs;
- defined small-signal perturbations or injected signals to enable assessment of control interaction behaviour;
- switching of static or dynamic reactive devices;
- load rejection events;
- operation at maximum and minimum transformer tap positions; and
- correct implementation of rate-of-change limits.

The simulations must also be of sufficient duration and resolution to capture:

- oscillatory behaviour and damping characteristics;
- adverse control interaction between plant and network; and
- numerical instability or non-physical artefacts.

As a minimum, assessments must monitor:

- active power;
- reactive power;
- voltage; and
- frequency.

## 5.4 Representation of Physical Components

Submitted models must represent all identifiable physical components required where each block or a combination of blocks represents the dynamic behaviour and characteristics of a physical component.

*Note: This section deals specifically with full inverter-connected energy sources. DFIGs with an AC connection on the stator of the machine are only included in relation to the rotor connection.*

### 5.4.1 Aggregation of IBR

A typical IBR consists of multiple inverter units, generally of the same technology type and from the same OEM. Groups of inverter units are typically connected via low- or medium-voltage collector systems, with multiple feeders or cables connecting these groups to a substation. At the substation, one or more transformers step the voltage up to the transmission level at the point of connection.

For the purpose of system-level studies, it is more practical to aggregate the IBR station into a single equivalent model that accurately represents the combined electrical characteristics, control behaviour, limits, and dynamic performance of the individual inverter units and associated collector system.

If you choose to aggregate either the generating units or the collector system as part of your model, follow the guidance below.

#### 5.4.1.1 Individual Converter Unit

To avoid unnecessary computational effort and simulation runtime, individual inverter-connected units may be aggregated into a reduced number of equivalent units. The simplest aggregation approach is based on scaling principles, whereby the capacity of an individual inverter unit is scaled by the total number of identical units represented.

Alternatively, established aggregation techniques may be used. Where generating units are aggregated, the resulting model shall:

- represent the combined active and reactive power capability of all inverter-connected units; and
- include an aggregated representation of the unit transformers associated with the inverter units.

### 5.4.1.2 Collector System

The size of your collector network dictates the aggregation approach you should take, as follows:

- For small collector networks, a single aggregated representation may be used, where the collector system is represented by an equivalent impedance capturing the combined voltage drop and losses of the internal network.
- For large or electrically extensive collector networks, collector system dynamics shall be represented more explicitly. In such cases, the station may be modelled as a combination of multiple subsystems, where each subsystem represents a cumulative and independent connection to a medium-voltage collector bus, consistent with established aggregation methods, such as the NREL method<sup>1</sup>.

The collector system representation must:

- include an equivalent feeder or collector impedance suitable for steady-state power-flow studies;
- be based on accurate and up-to-date impedance data;
- preserve the steady-state characteristics relevant to electrical location of inverter groups relative to the point of connection where this materially affects model performance; and
- preserve characteristics identified in power-flow studies, such as losses and voltage drop attributable to the aggregated units.

You must model the grid-tie transformer explicitly, including any tie-line impedance to the POC, with fixed tap settings correctly represented. Also include reactive power compensation devices and transformer on-load tap changer controls, where installed.

See Impedance Requirements Appendix E for a list of the typical impedance information to be submitted along with the model.

Figure 2 illustrates a typical example of an aggregated IBR station.

Figure 2: Typical Aggregated IBR Station

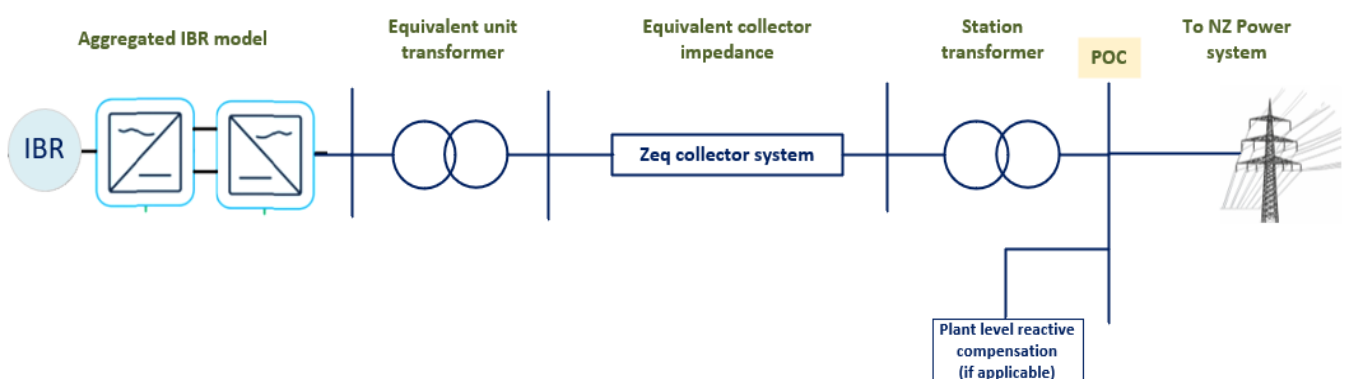

<sup>1</sup> E. Muljadi, C. P. Butterfield, A. Ellis, J. Mechenbier, J. Hochheimer, R. Young, N. Miller, R. Delmerico, R. Zavadil, and J. C. Smith, "Equivalentencing the collector system of a large wind power plant," in Proc. IEEE Power Eng. Soc. General Meeting, Montreal, QC, Canada, Jun. 2006.

## 5.4.2 Configuration of IBR

IBR stations may be configured using a single primary energy source or, as hybrid installations, comprising multiple primary energy sources. Refer to the sections below for typical modelling your IBR type.

### 5.4.2.1 Single-source IBR

A typical single-source IBR consists of multiple inverter units, generally of the same technology type and from the same OEM, supplied by a common primary energy source such as wind, solar photovoltaic, or battery energy storage. Figure 2 above illustrates a typical example of an aggregated single-source IBR station.

A dynamic model of a single-source IBR typically consists of:

- a plant-level controller, representing supervisory control and coordination functions;
- a voltage and reactive power control system (electrical control), including relevant limiters and supplementary control functions; and
- a converter (inverter) model, including associated protection and current-limiting functions.

Additionally, for DFIG type wind turbines, the dynamic model typically includes:

- a torque controller model;
- a pitch controller model;
- an aerodynamic model representing wind-to-mechanical power conversion; and
- a drive-train model representing the mechanical coupling between turbine and generator.

### 5.4.2.2 Hybrid Plants

Hybrid plants combine two or more inverter-based resource technologies within a single generating station, with shared or coordinated electrical and control infrastructure. In a typical hybrid plant, each resource type shall be represented by its own aggregated power-flow model.

Multiple configurations are possible with hybrid plants. Some of the more common configurations are:

- DC-coupled PV solar or WTG and BESS, with a common DC-to-AC inverter; and
- AC-coupled PV and BESS, such that each of the two assets have their own independent DC-to-AC inverters as well as their own AC transformers.

Figure 3 and Figure 4 below illustrate typical examples of hybrid IBR stations and the aggregation of hybrid IBR stations respectively.

Figure 3: Typical Hybrid IBR Stations

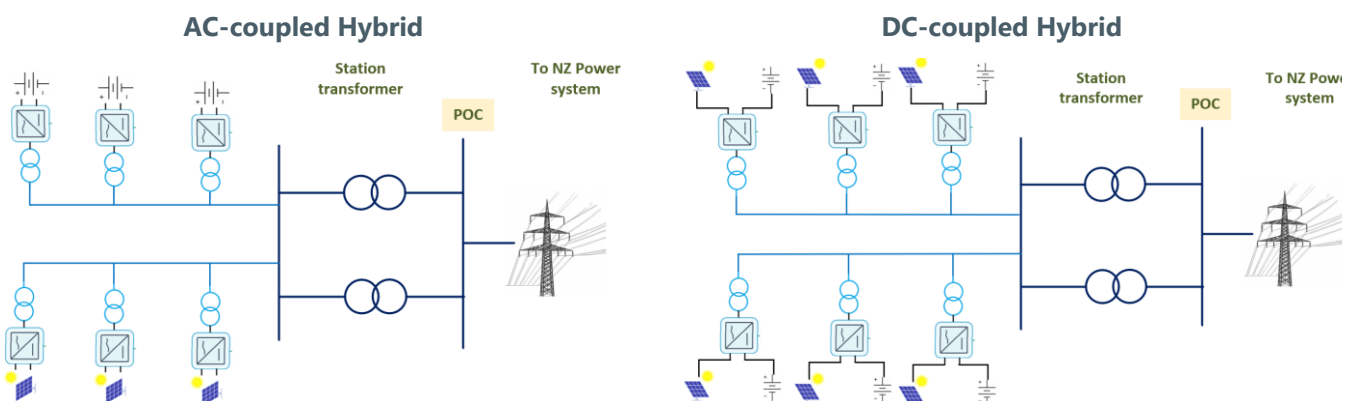
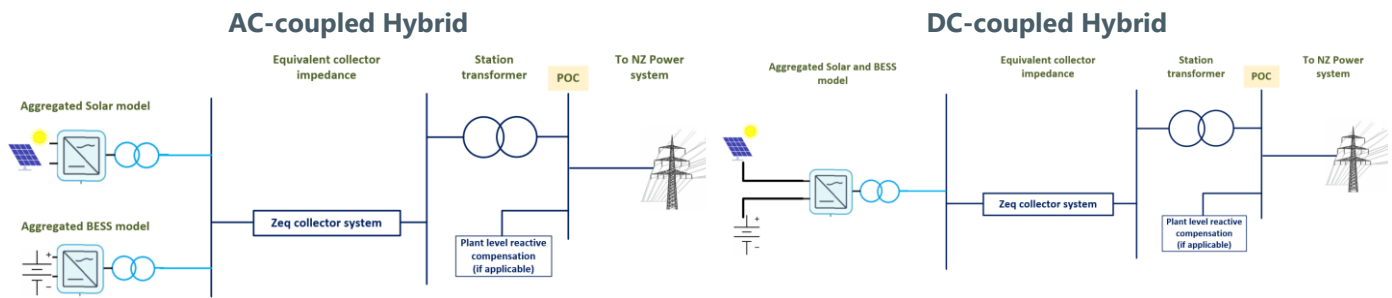

Figure 4: Typical Aggregation of Hybrid Stations



Given there are at least four different types of hybrid configurations, we recommend asset owners engage with the System Operator to agree an appropriate modelling approach for their specific hybrid plant.

### 5.4.3 Dynamic Model and WECC mapping

The dynamic model of your IBR must include the major components outlined in Table 5. See Figure 5 below that for how these might be mapped on a typical IBR control diagram and equivalent WECC controller.

Table 5: IBR major components and their functions

| Component                                    | Typical Function  |
|--|---|
| Power plant controller                       | <ul style="list-style-type: none"> <li>to process frequency and active power output to emulate active power control; and</li> <li>to process active and reactive power commands to the electrical control module; and</li> <li>to process voltage and reactive power dispatch commands at the plant level.</li> </ul> |
| Electrical P/Q controller with limiters      | <ul style="list-style-type: none"> <li>to act as active and reactive power reference from the plant control module with feedback from terminal voltage and generator power output; and</li> <li>to provide real and reactive current commands to the generator/converter module.</li> </ul>                           |
| Generator/converter                          | <ul style="list-style-type: none"> <li>to process the active and reactive current commands; and</li> <li>to process the active and reactive current injection into the power system.</li> </ul>   |
| Turbine (if applicable, e.g. on a wind farm) | <ul style="list-style-type: none"> <li>aerodynamics (single wind speed data is acceptable);</li> <li>pitch controller; and</li> <li>torque controller.</li> </ul>   |
| Generator protection                         | <ul style="list-style-type: none"> <li>tripping logic for under- and over-frequency and under- and over-voltage should be implemented using standard generator protection models, if possible;</li> </ul>   |

Figure 5 : Typical Components of an IBR Control System &amp; their Equivalent WECC Model

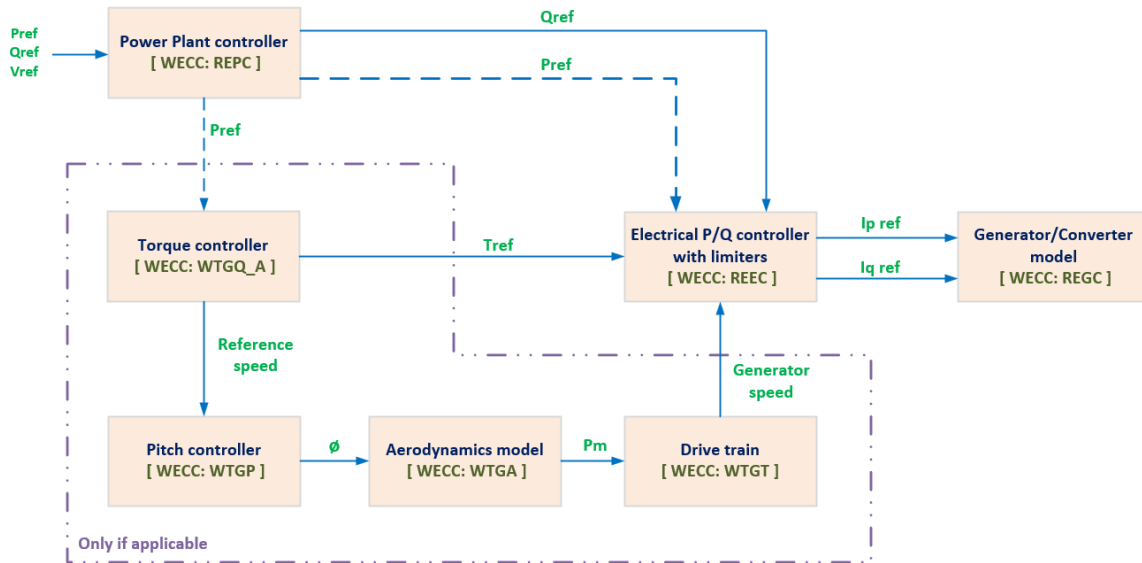

#### 5.4.4 Reactive Power Capability

Reactive power requirements are specified at the POC. The impedance of the collector system affects how the IBR delivers reactive power at the POC. Therefore, the reactive power capability of the station must match the capability at the POC.

The reactive power capability curve shall :

- include power factor correction capacitors at the individual inverter level, if any (typically, modern DFIG and full-scale converter type wind turbine generators do not employ power factor correction shunt capacitors or any other shunt devices at the WTG level, since they have full and independent control of active and reactive power at the WTG level); and
- exclude reactive power compensation devices at station level – model these separately.

### 5.5 Dynamic Reactive Power Compensation Devices

Dynamic reactive power compensation devices, such as Static Var Systems (SVS), STATCOMs, and SVCs, may be installed at or electrically close to IBR stations or at grid level to support voltage regulation and system stability.

Where present, these devices shall be represented in system-level models with sufficient fidelity to capture their interaction with IBR control systems and the transmission network. Devices that consist solely of discretely switched shunt elements without dynamic control capability may be represented as fixed or switched reactive resources, provided this does not materially affect study outcomes.

The user guide accompanying the model must describe the operating principles, control modes, limits, and protection functions of the reactive compensation device. Where appropriate, supporting diagrams (e.g. block diagrams, mode transition diagrams, or voltage control characteristics) may be provided to aid interpretation.

A capability diagram must be provided where applicable, identifying operating limits, overload capability, and any supplementary control functions such as power oscillation damping (POD).

Typical features and parameters that shall be represented in the model are listed in Table 6 below.



Table 6 : Dynamic Reactive Power Compensation System Modelling Requirements

| Feature   | Requirements that must be Modelled  |
|---|---|
| Voltage Control Modes (including voltage control at nominated bus, SVS Var output control, and manual control mode) | Representation of applicable voltage or reactive power control modes, including steady-state and disturbance response behaviour. Different control modes and associated settings (e.g. fast/slow control function, droop, deadband, time delay) must be represented where they materially affect system response. |
| Switched Shunts   | Automated switching of shunt devices where used to manage reactive output, maintain operating headroom, or support voltage recovery following disturbances.   |
| Overload Capability   | Temporary overload capability used for voltage support, including interaction with shunt switching or other mechanisms used to relieve overload conditions.   |
| Gain adaptation   | Any automatic or dynamic gain reduction functions used to maintain stability under varying network strength, including the conditions under which such functions are activated.   |
| Control mode transitions  | Transitions between control modes (e.g. steady-state and disturbance response modes). These must be represented in a manner that avoids artificial discontinuities and reflects the implemented control logic.  |
| Key parameters  | Key parameters influencing dynamic behaviour, including gains, droops, trigger thresholds, time delays, and relevant protection settings.   |

## 6 Testing

### 6.1 Testing Parameter Integrity

All testing must be conducted using the final (as-left) set of parameters. Once testing has commenced, no changes to model parameters are permitted. If any model parameter is modified at any stage, all previously completed tests must be repeated in full using the updated parameter set.

This requirement ensures:

- the integrity and traceability of test results;
- consistency between tested and submitted models; and
- that test outcomes remain valid for the final parameter configuration.

### 6.2 Measurement Points

Record measurement signals as specified in Table 7 below:

*Table 7 : Measurement Signal Points for Inverter-Based Resources*

| Measurement Signal Locations   | Specific Signals to Record   |
|--|--|
| At the individual unit <sup>2</sup> level – i.e. either: <ul style="list-style-type: none"> <li>▪ at the WTG level (for example, for factory type testing)</li> <li>▪ or at the solar inverter string,</li> <li>▪ or other inverter connected module.</li> </ul> | <ul style="list-style-type: none"> <li>▪ inputs and outputs of the unit for validating individual unit model/inverter string model/module model; and</li> <li>▪ internal signals such as converter DC voltage and PLL (phase-locked loop) input and output, if accessible.</li> </ul>          |
| At the overall plant level   | <ul style="list-style-type: none"> <li>▪ inputs to plant controller;</li> <li>▪ outputs to individual WTG, inverter string or module;</li> <li>▪ active and reactive power at the POC, if applicable; and</li> <li>▪ outputs to reactive power compensation devices, if applicable.</li> </ul> |

Refer to the Figure 6 to locate the measurement points on typical IBR generation assets.

The list of signals to be measured are indicated in our [GL-EA-010 Generator Testing Requirements](#) document.

<sup>2</sup> For field testing at the station level, it may not be necessary to record all individual units; where needed, you might record only representative units in the station.

Figure 6: Typical IBR Configuration and Measurement Points

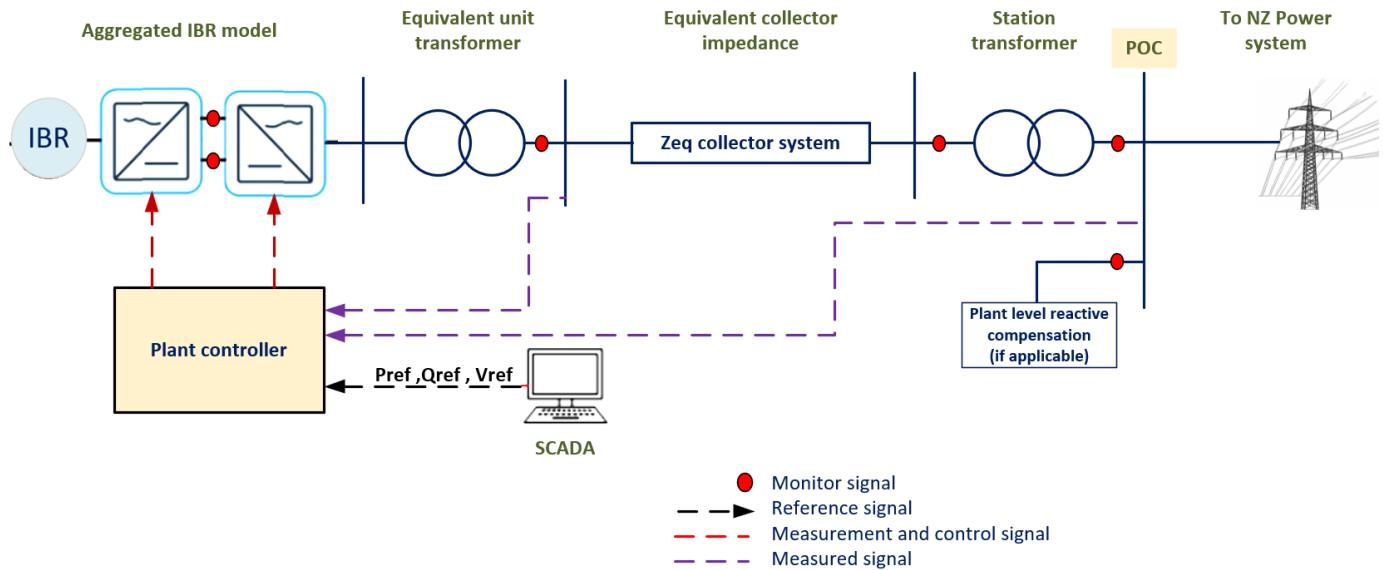

### 6.3 Commissioning and Routine Testing

Follow the guidance in [GL-EA-010 Generator Testing Requirements](#), especially as it pertains to IBRs.

The testing for IBRs consists of:

- factory type tests for individual inverter performance;
- plant level frequency and voltage step tests; and
- plant level over-frequency tests etc.

The testing for a BESS is essentially the same as for a WPP or SPP. The one additional test that may be required is the under-frequency test, since a BESS should be able to provide both over- and under-frequency response when not at the limits of its state of charge.

### 6.4 Validation against Test Data

After testing, you must re-create the operating conditions to validate your model. These simulations must ensure the adequacy, reliability, and accuracy of your models. Validate your models in conjunction with the equipment manufacturer, where possible, especially for new installations. Commissioning is a good time to ensure alignment of simulated model response against measured test results while the manufacturer is on-hand.

Often, manufacturer-sourced models are created using one or more of the following techniques:

- theoretically derived, based on the design of plant; and/or
- formed after analysis of operational data from other similar equipment installed elsewhere.

The equipment manufacturer is in the best position to advise you on model performance, expectations, and any limitations, particularly where equipment is connected to weaker parts of the power system.

*The System Operator will accept the PowerFactory and PSCAD models once the following conditions are met:*

- *The models have been validated against test results using the same test steps and conditions applied during commissioning or compliance testing; and*
- *The simulated responses are demonstrated to be within the model acceptance criteria specified in Appendix F.*

A TSAT model must be benchmarked against the corresponding validated PSCAD model. Conduct benchmarking tests in accordance with the requirements specified in section 77.1. Where you are unable to undertake the required benchmarking of the TSAT model against the validated PSCAD model, the System Operator may, by agreement, undertake the benchmarking on your behalf. Any such support shall be subject to an agreed scope of work and cost-recovery arrangement.

## 6.5 M2 Model Parameter Integrity

Model validation must be performed using the final, as-left set of parameter values. Any change to a model parameter after validation, including but not limited to changes to PID gains, time constants, limits, dead-bands, ramp rates, or control logic, shall invalidate the previously completed validation.

Where any parameter value is modified, repeat all applicable validation testing using the updated parameter set.

*Note: For clarity, adjusting PID gains or time constants during validation testing to obtain results at different operating points, or using different parameter sets for different tests **is not acceptable as model validation**. Only validation results obtained using a single, consistent, final parameter set can be considered valid for model acceptance.*

Where, during validation, it is necessary to adjust model parameters from the values implemented in the actual control system, such adjustments must **not exceed  $\pm 5\%$**  of the corresponding as-left parameter values. Ensure that any such parameter adjustments are fully justified and clearly documented in the validation report.

## 6.6 Network Model Integration

You must incorporate the validated model into the respective PowerFactory cases provided on the [Electricity Authority's website](#) or the [EMT zonal](#) network model, and the tests specified in sections 6.6.1 and 6.6.2 must be performed to confirm acceptable performance under system conditions.

### 6.6.1 No Disturbance Response

This must be demonstrated through a no-disturbance simulation of at least:

- 120 seconds for RMS simulation; and
- 30 seconds for EMT simulation,

during which the model remains within the limits specified in Table 4.

The no-disturbance test will confirm the stable behaviour of active power, reactive power, voltage, and frequency, with no unintended oscillations, drifts, or numerical instability.

### 6.6.2 Disturbance Response

The performance of the network-integrated model must be demonstrated by applying the following system-level disturbances, as appropriate, to verify the dynamic response of the asset within the wider network:

- balanced and unbalanced network faults, including:
  - For RMS simulations
    - three-phase-to-ground (3-ph-G) for 120ms faults; and
  - For EMT simulations
    - three-phase-to-ground (3-ph-G) for 120ms faults; and
    - two-phase-to-ground (2-ph-G) for 120ms faults;
- under-frequency events, represented by tripping of the largest generating unit within the relevant island; and
- over-frequency events, represented by tripping of a large system load within the relevant island.



The simulations must demonstrate that the integrated model responds appropriately to these disturbances and remains stable following fault clearance and system recovery.

## 6.7 Validation Report

You must submit a validation report that meets our requirements. Ensure that it:

- follows the report template in Appendix B;
- clearly demonstrates equipment performance and capability based upon either manufacturer data, test data, or simulation results as agreed with the System Operator; and
- includes:
  - the user guide(s) outlined in section 4.4.
  - a statement explaining how the model meets the model quality requirements and satisfies model acceptance criteria specified in this guideline;
  - details of any identified performance limitations, assumptions, or constraints;
  - all recorded test results compiled in respective cases, used to support model validation; and
  - any other supporting information not listed above that the System Operator reasonably requires to utilise and translate the model into other software platforms.

To facilitate your gathering of information, refer to the checklist in Appendix A.

## 7 Benchmarking

Benchmarking is required to demonstrate that the TSAT RMS model provides an acceptable representation of the dynamic behaviour of the asset when compared against a validated PSCAD EMT model. For this comparison, use as-left parameters under identical network conditions, control modes, operating points, and disturbance scenarios, thereby confirming the model's suitability for transient stability and security assessment studies. See the model acceptance criteria defined in Appendix F for the assessment.

### 7.1 Benchmarking Test Setups

Set up your tests according to the figures and measured quantities below:

Figure 7: SMIB Setup in TSAT (modify as necessary)

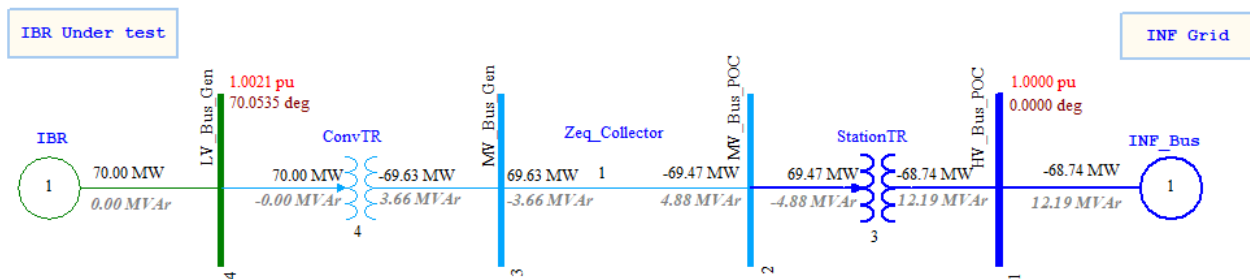
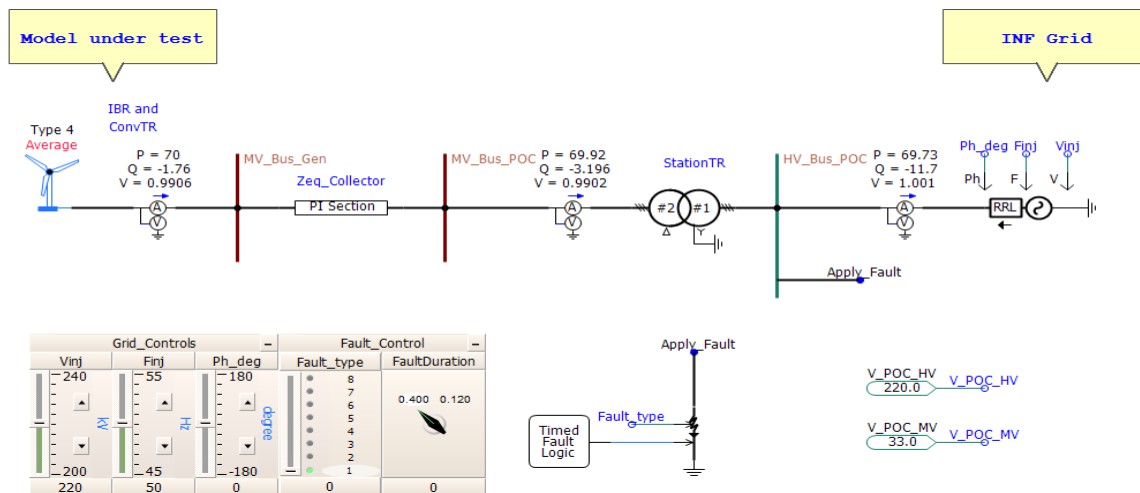

Figure 8: SMIB Setup in PSCAD (modify as necessary)



Measured Quantities:

- POC bus voltage – 3 phase RMS (pu)
- POC frequency (Hz)
- Plant active power (MW)
- Plant Reactive power (Mvar)
- Control signals (as applicable): dq axis voltage and currents (Vd,Vq, id, iq), PLL angle/frequency
- FRT flags, Protection flags

## 7.2 Benchmarking Tests

### 7.2.1 No Disturbance Test

**Objective:** To validate steady-state stability and numerical robustness.

**Test 1:** No disturbance for 120 seconds.

**Test 2:** Change in simulation time step (1 ms, 5 ms, 10 ms).

**Acceptance Criteria:**

- Voltage and frequency remain within  $\pm 0.5\%$  of setpoint.
- No sustained oscillations or numerical divergence.
- Time step sensitivity checks results stable for  $\Delta t$  variations.

### 7.2.2 Voltage Step Test

**Mode:** Voltage control enabled ( $V_{\text{setpoint}} = 1.0$  pu)

Table 8 : Voltage Step Test Matrix

| Sr no | SCR | X/R | P (pu) | Grid Voltage Step | Test |
|-------|-----|-----|--------|-------------------|------|
| 1     | 3   | 5   | 0.5    | $\pm 3\%$ step    |      |
| 2     | 3   | 5   | 1      | $\pm 3\%$ step    |      |
| 3     | 3   | 10  | 0.5    | $\pm 3\%$ step    |      |
| 4     | 3   | 10  | 1      | $\pm 3\%$ step    |      |
| 5     | 10  | 5   | 0.5    | $\pm 3\%$ step    |      |
| 6     | 10  | 5   | 1      | $\pm 3\%$ step    |      |
| 7     | 10  | 10  | 0.5    | $\pm 3\%$ step    |      |
| 8     | 10  | 10  | 1      | $\pm 3\%$ step    |      |

**Acceptance Criteria:**

- Transient response meets limits as per Appendix F when comparing PSCAD and TSAT model responses.

### 7.2.3 Frequency Step Test

**Mode:** Frequency control enabled

Table 9 : Frequency Step Test Matrix

| Sr no | SCR | X/R | P (pu) | Grid Frequency Step | Test |
|-------|-----|-----|--------|---------------------|------|
| 1     | 3   | 5   | 0.5    | $\pm 2\%$ step      |      |
| 2     | 3   | 10  | 0.5    | $\pm 2\%$ step      |      |
| 3     | 10  | 5   | 0.5    | $\pm 2\%$ step      |      |
| 4     | 10  | 10  | 0.5    | $\pm 2\%$ step      |      |

**Acceptance Criteria:**

- Transient response meets limits as per Appendix F when comparing PSCAD and TSAT model responses.

## 7.2.4 Frequency Controller Priority test

**Mode:** Frequency control enabled

### Step 1: Initialisation and dispatch

- The plant shall be initialised at steady-state at:
  - Frequency = 50 Hz
  - Active power output = 0.2 pu
- The plant shall then be dispatched upwards (Dispatch set point = 1 pu) using the configured dispatch ramp rate.

### Step 2: Frequency disturbance during dispatch

- During the dispatch ramp (target range: 0.4–0.5 pu active power), a frequency disturbance shall be applied:
  - Negative step change (under-frequency) of -1% relative to nominal frequency.
- During the disturbance, the plant shall respond with an active power ramp consistent with its defined frequency response ramp. The response shall continue until the active power output reaches the pre-disturbance MW operating level plus the droop-based MW contribution corresponding to the frequency deviation (see figure below).

### Step 3: After Droop based response

- The plant shall revert to dispatch control
- Active power shall continue to follow the pre-disturbance ramp rate

### Step 4 : Repeat the simulation for over frequency step

- Perform separate simulations for positive step change (over-frequency) of +1% relative to nominal frequency when the plant is dispatched down from 1pu to 0.2pu.

Please refer to figure below to understand test and expected response

*Frequency controller priority testing*

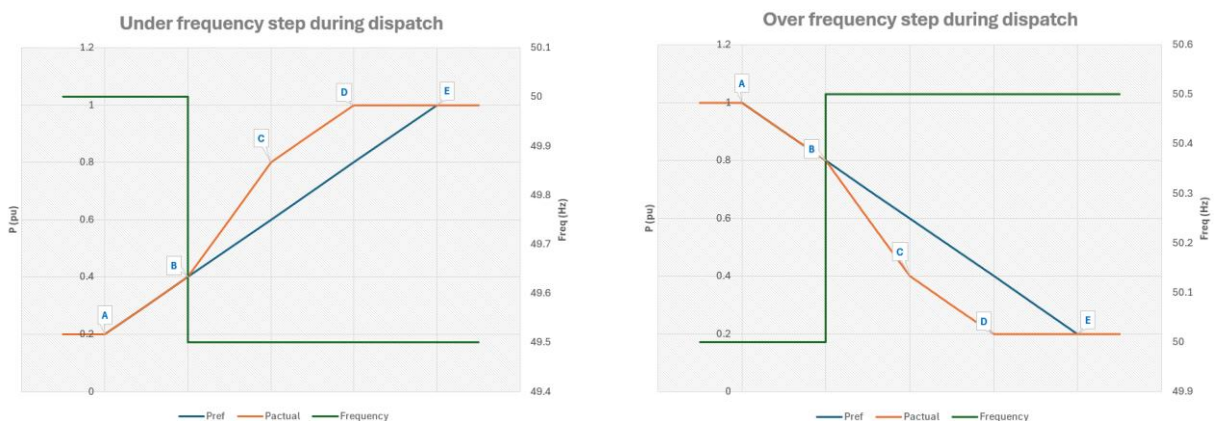

**Pref:** Active power reference from PPC to inverter

**Pactual:** Measured inverter active power output

Expected response

- Pref trajectory
  - A–B–E: Active power setpoint follows the dispatch ramp rate
- Pactual trajectory
  - A–B: Active power follows dispatch ramp rate under normal operation
  - B–C: Active power follows frequency response ramp rate and the settling point (point C) shall be as per combined effect of:
    - ongoing dispatch ramp, and
    - droop-based frequency response
  - C–D: Once the droop response is fully delivered, active power continues at dispatch ramp rate

### 7.2.5 Fault Response Test

**Mode:** Voltage control enabled ( $V_{\text{setpoint}} = 1.0$  pu)

*Table 10 : Fault Response Test Matrix*

| Sr no | SCR | X/R | P (pu) | Fault                   |
|-------|-----|-----|--------|-------------------------|
| 1     | 3   | 5   | 0.5    | 3ph-G , 120ms @ Bus_POC |
| 2     | 3   | 5   | 1      | 3ph-G , 120ms @ Bus_POC |
| 3     | 3   | 10  | 0.5    | 3ph-G , 120ms @ Bus_POC |
| 4     | 3   | 10  | 1      | 3ph-G , 120ms @ Bus_POC |
| 5     | 10  | 5   | 0.5    | 3ph-G , 120ms @ Bus_POC |
| 6     | 10  | 5   | 1      | 3ph-G , 120ms @ Bus_POC |
| 7     | 10  | 10  | 0.5    | 3ph-G , 120ms @ Bus_POC |
| 8     | 10  | 10  | 1      | 3ph-G , 120ms @ Bus_POC |

**Acceptance Criteria:**

- Fault ride-through as per Code obligations.
- Post-fault recovery meets limits as per Appendix F when comparing PSCAD and TSAT model responses.

### 7.2.6 Modulation/Oscillation Test

**Mode:** Voltage control enabled ( $V_{\text{setpoint}} =$  appropriate to  $\pm 0.3$  pu reactive power)

**SCR:** Lower of 3 or POC (i.e. lowest ESCR as identified by short circuit studies)

See Figure 9 for an example of a voltage oscillation at 1 Hz.

*Table 11 : Modulation/Oscillation Test Matrix*

| Sr no | P (pu) | Test  |
|-------|--------|---|
| 1     | 1      | $\Delta V$ 0.05 pu @ 1-30 Hz in step of 1 Hz, 10 sec excitation windows<br>Excitation window = minimum 10 cycle |
| 2     | 0.5    | Simulation window = initialisation period + excitation window + settling window                                 |

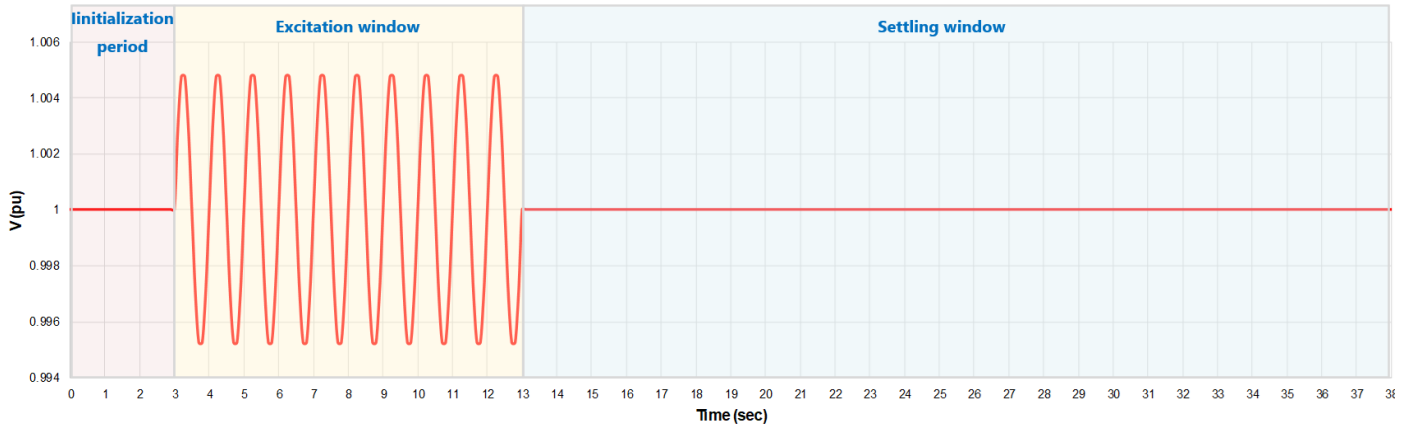

*Figure 9: Typical Simulation Window for 1 Hz Voltage Oscillation*

**Acceptance Criteria:**

- Limits as per Appendix F when comparing PSCAD and TSAT model responses.



## Appendix A. Model Submission Checklist

Use the checklist below to verify that you have progressed through the model submission process. If you have followed our guidelines, you should be able to check 'yes' to all of these.

| ID                  | Description  | Check               |  |             |  |              |  |  |
|---------------------|--|---------------------|--|-------------|--|--------------|--|--|
| <b>1</b>            | <b>Model Development - PowerFactory, PSCAD and TSAT model</b>  |                     |  |             |  |              |  |  |
| A                   | Is the model developed as per software package and version outlined in section 4.1?  |                     |  |             |  |              |  |  |
| B                   | Is model developed with encryption requirements as per section 5.1?  |                     |  |             |  |              |  |  |
| C                   | Have you confirmed the confidentiality status of your models (tick below as appropriate)? <table border="1" style="width: 100%; border-collapse: collapse;"> <tr> <td style="width: 30%;"><b>PowerFactory</b></td> <td>Confidential: <input type="checkbox"/></td> </tr> <tr> <td><b>TSAT</b></td> <td>Confidential: <input type="checkbox"/></td> </tr> <tr> <td><b>PSCAD</b></td> <td>Confidential: <input type="checkbox"/></td> </tr> </table> | <b>PowerFactory</b> | Confidential: <input type="checkbox"/> | <b>TSAT</b> | Confidential: <input type="checkbox"/> | <b>PSCAD</b> | Confidential: <input type="checkbox"/> |  |
| <b>PowerFactory</b> | Confidential: <input type="checkbox"/>   |                     |  |             |  |              |  |  |
| <b>TSAT</b>         | Confidential: <input type="checkbox"/>   |                     |  |             |  |              |  |  |
| <b>PSCAD</b>        | Confidential: <input type="checkbox"/>   |                     |  |             |  |              |  |  |
| D                   | If the model is confidential, is the generic model developed as per WECC format?   |                     |  |             |  |              |  |  |
| E                   | Does the model represent physical components as outlined in section 5.4?   |                     |  |             |  |              |  |  |
| F                   | Is the model provided with user guide with all details mentioned in section 4.4?   |                     |  |             |  |              |  |  |
| <b>2</b>            | <b>Model Testing</b>   |                     |  |             |  |              |  |  |
| A                   | Has the model been tested in SMIB?   |                     |  |             |  |              |  |  |
| B                   | Has the model been tested in PowerFactory cases <a href="#">provided by the Electricity Authority</a> ?  |                     |  |             |  |              |  |  |
| C                   | Has the model been tested in EMT case?   |                     |  |             |  |              |  |  |
| D                   | Does the model meet the quality requirements of section 5?   |                     |  |             |  |              |  |  |
| E                   | Does the model initialise as per the initialisation requirements of section 5?   |                     |  |             |  |              |  |  |
| <b>3</b>            | <b>Model Validation and Documentation</b>  |                     |  |             |  |              |  |  |
| A                   | Is the model validated across the whole range of active power, reactive power and voltage?   |                     |  |             |  |              |  |  |
| B                   | Does the model validation process meet the acceptance criteria as per Appendix F?  |                     |  |             |  |              |  |  |
| C                   | Does the validation process respect parameter integrating requirements outlined in section 6.5?  |                     |  |             |  |              |  |  |
| D                   | Does the validation report follow the template in Appendix B?  |                     |  |             |  |              |  |  |
| E                   | Is the TSAT model benchmarked according to the requirements of section 7?  |                     |  |             |  |              |  |  |
| F                   | Are the test results added as part of M2 model submission package?   |                     |  |             |  |              |  |  |

## Appendix B. Validation Report Template

### Report Structure

Your should submit your validation report in either Adobe Portable Document format (PDF) or Word Document format (DOCX). Every report must consist of the following sections:

- Cover page
- Table of contents
- Revision history
- Completed checklist ( prepare as per appendix A)
- Description of plant connection
- Description of generator connection
- Description of control system
- User guide as outlined in section 4.4
- Plots demonstrating models validated against test results ( See **Error! Reference source not found.** )
- The test procedure
- Description of the data files submitted, including units of measure; where per-unit (pu) values are recorded the base value used must be explicitly stated
- Accompanying data file containing all test results and model simulation results in table form with appropriate column headings.

### Cover Page

Each model validation report must have a cover page that displaying the following information:

- Station name
- Test unit name and ID
- The name of the engineer responsible for writing the model validation report
- The name of the person who has reviewed the model validation report
- The name of the person who has approved the model validation report
- The name of the System Operator engineer who witnessed the testing (if any)
- The date on which the tests were performed
- The date the report was submitted
- The name, date and version of the PowerFactory, TSAT or PSCAD model the report refers to.

### Table of Contents

Each model validation report must have a table of contents with the main sections showed below.

1. Model validation checklist
2. Plant connection description
  - 2.1. Single line diagram
  - 2.2. Plant electrical parameters
    - 2.2.1. Plant rating (MVA)
    - 2.2.2. Unit transformer information
    - 2.2.3. Auxiliary loads
    - 2.2.4. Fuel type
3. IBR description
  - 3.1. Aggregation of IBR
  - 3.2. IBR EMT model
  - 3.3. IBR RMS Model
  - 3.4. IBR model benchmarking
4. Result of frequency control system validation
  - 4.1. ..

5. Results of volage control system validation
  - 5.1. ..
6. Result of POD and Limiters validation
  - 6.1. ..
7. Discussion of results and limitations identified
  - 7.1. ..
8. Supporting documents
  - 8.1. Nameplates and data sheet
  - 8.2. User guide prepared as per section 4.4
  - 8.3. PowerFactory model and library files (if any)
  - 8.4. PSCAD model and library files (if any)
  - 8.5. TSAT model and library files (if any)
  - 8.6. WECC model (if applicable)
  - 8.7. Recorded test results in .CSV format.
  - 8.8. Test procedure
  - The results are best compared using graphical methods. An example of such a comparison is shown in the Figure 10 below.

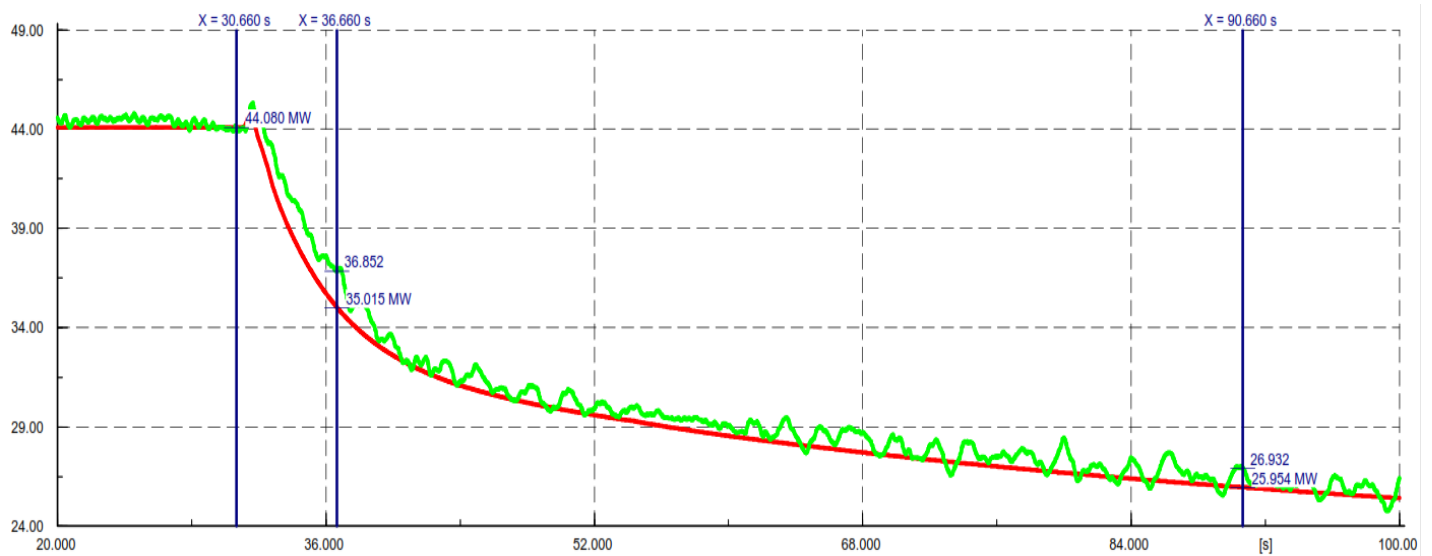
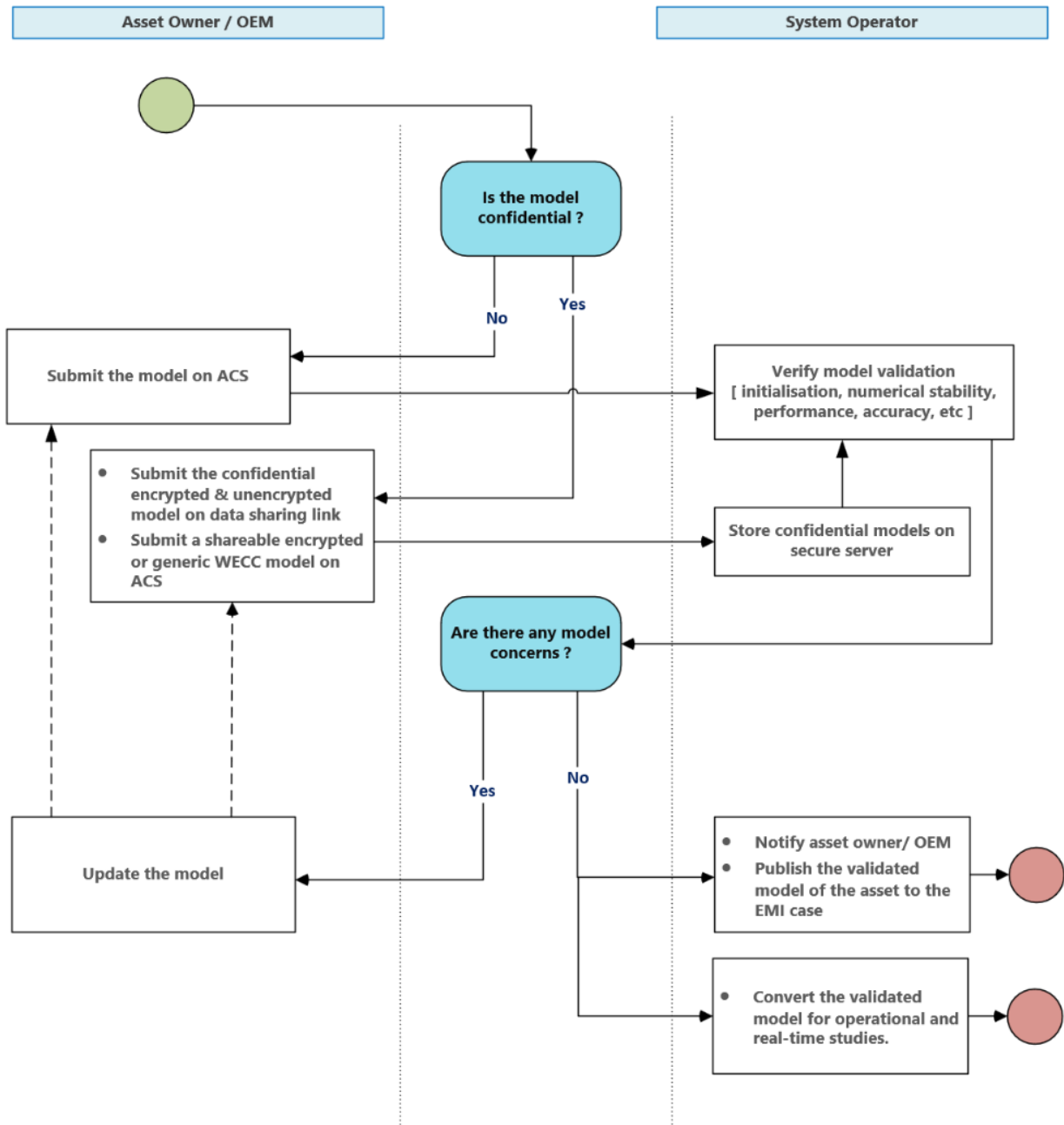
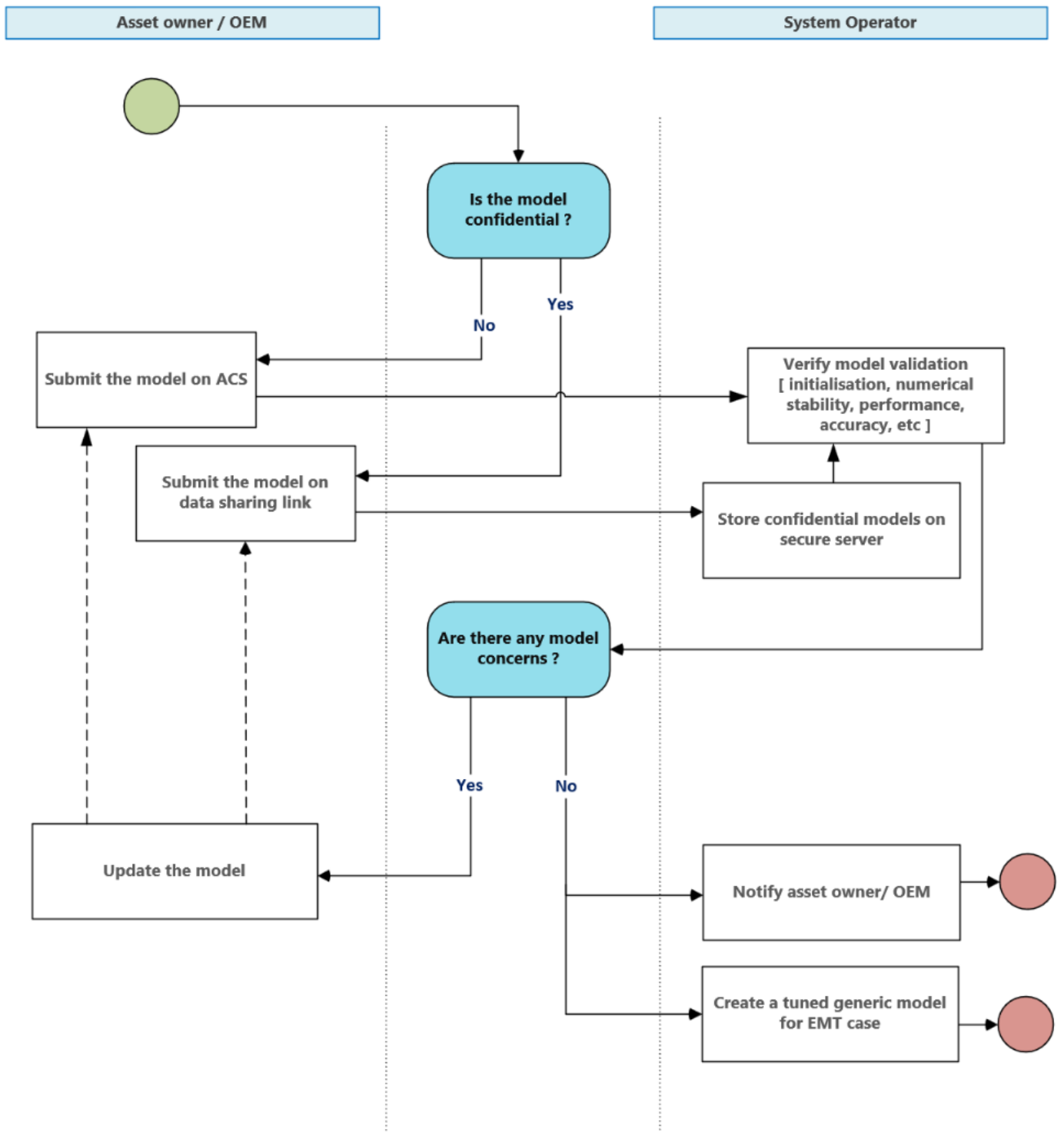

Figure 10: Example Plot showing 'Good Fit' between Model Performance and Test Results

## Appendix C. Process for RMS Model Submission



## Appendix D. Process for EMT Model Submission



## Appendix E. Impedance Requirements

### E.1 Grid-connected IBR Stations

A typical IBR generation station may have several strings of inverters, each with one or more inverters connected to it. The connection impedances between the inverters and POC affects the reactive power output of the station. It is essential to accurately model reactive power capability to assess the voltage stability of the grid. It is therefore necessary to account for the collector system impedances and their combined effect on the reactive power capability of the station. See Figure 11 for typical arrangements for WPP and SPP.

Figure 11: Typical Grid-connected IBR Arrangements

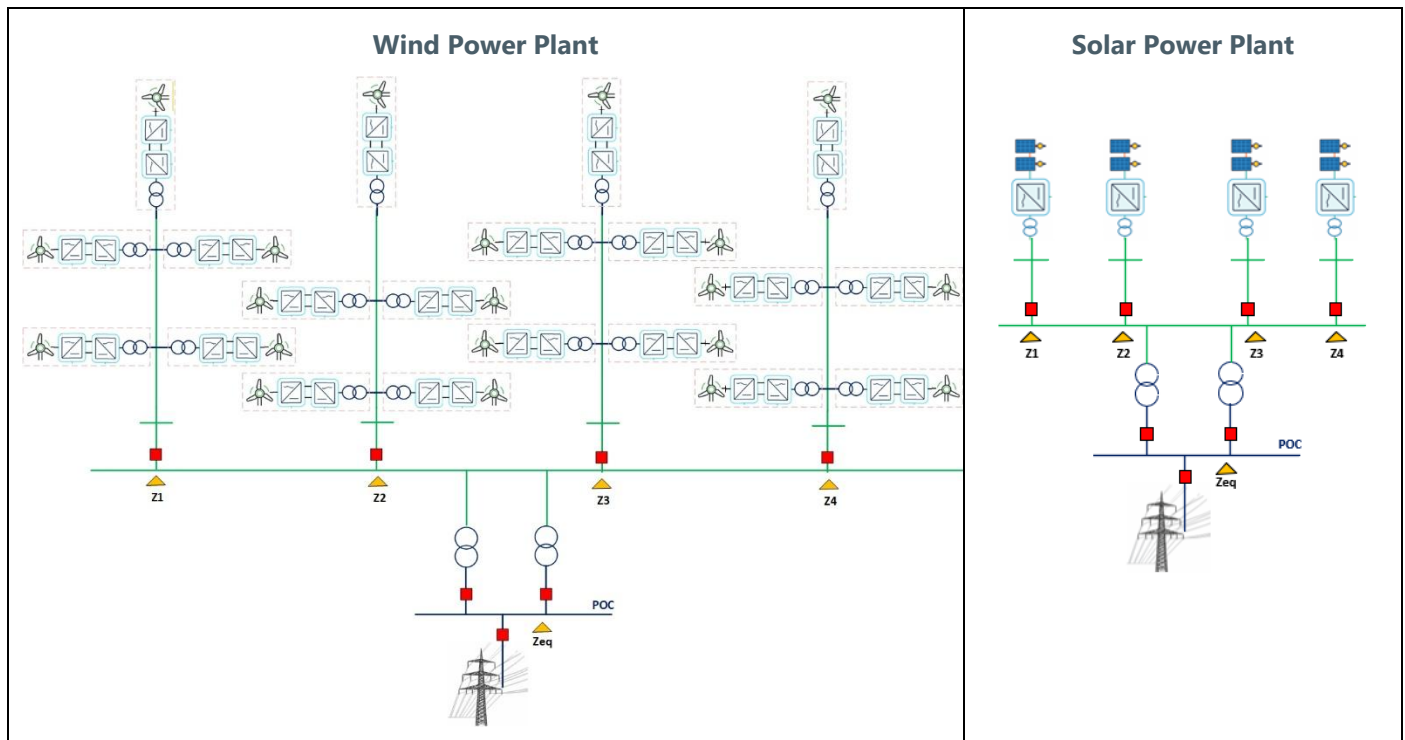

Ensure you validate your model considering the collector system and include the aggregated impedances in your validation report. You must submit the following:

- The cumulative impedance of the station as seen from POC ( $Z_{eq}$ ): this is the total impedance of the station equipment, transformers, cables, and other components that are connected to the grid at the POC.
- The impedance of each string of inverters between the inverter terminals and the collector system bus/station transformer LV (Low Voltage) terminals. ( $Z_1, Z_2, Z_3, Z_4$ ) – this is the cumulative impedance of the inverter output filters, cables, fuses, and other components of each string.

### E.2 Embedded IBR Stations

Small-scale wind or solar or BESS are typically connected to a local network rather than the grid. These stations often include one or more inverters connected through a collector system to the POC at the distribution network. See Figure 12 for typical arrangements for wind and solar IBRs.

Figure 12: Typical Embedded IBR Arrangements

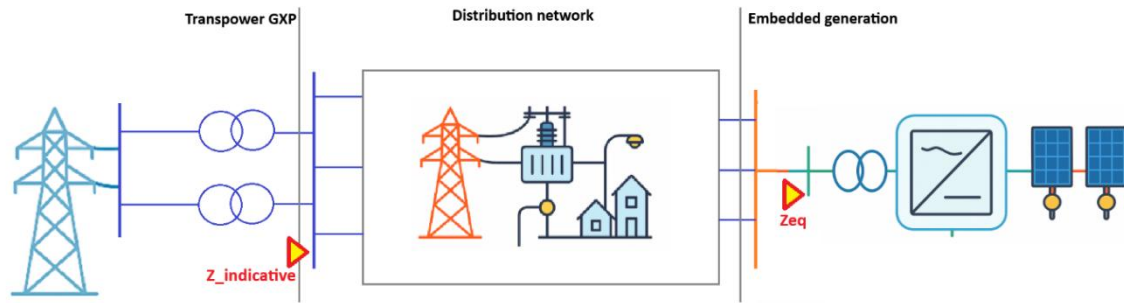

Ensure you validate your model considering the collector system and include the aggregated impedances in your validation report. You must submit the following:

- $Z_{indicative}$ : an approximate impedance value at the Grid Exit Point (GXP), representing the downstream distribution (sub-transmission) network impedance between GXP and POC of embedded generation.
- Cumulative impedance of station as seen from POC ( $Z_{eq}$ ): this is the total impedance of the station equipment, transformers, cables, and other components that are connected to the grid at the POC.

## Appendix F. Model Acceptance Criteria

### F.1 Steady-State Response (No Disturbance)

**Numerical Robustness:** No solver divergence or instability during RMS and EMT runs.

Active power, reactive power, voltage and frequency remain within acceptable range below for 120 seconds (RMS) and 30 seconds (EMT).

| Quantity              | Acceptable range                          |
|-----------------------|---|
| Generator MW and MVAR | Within $\pm 1\%$ of MW and MVAR setpoint  |
| Controlled voltages   | Within $\pm 0.005$ pu of Voltage setpoint |

### F.2 Transient Response: Step Change Test and Benchmarking

Figure 13: Transient Window Definition

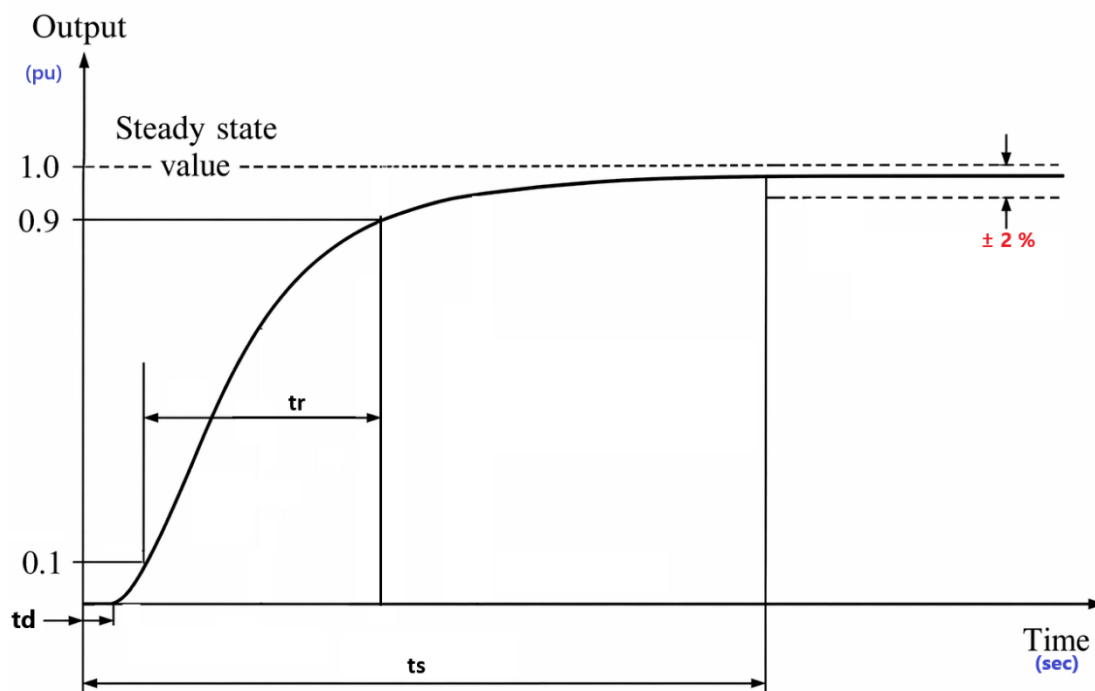

The above measurements are defined as follows:

- Delay time (**td**): Time from the application of a disturbance (e.g., step change, fault) to the initial observable response in the output variable (such as voltage, active power, or frequency).
- Rise time (**tr**): Time taken for the output to rise from 10% to 90% of the total induced change following a disturbance.
- Settling time (**ts**): Time required for the output to remain within a specified tolerance band (typically  $\pm 2\%$  of the final value) following a disturbance.

Table 12: Acceptance Criteria for Transient Response

| Category           | Metric | Criteria   |
|--------------------|--------|--|
| Delay Time (td)    | IBR    | 0.01–0.1 sec   |
| Rise Time (tr)     | IBR    | 0.05–0.5 sec   |
| Settling Time (ts) | IBR    | 0.5–3 sec (RMS), 1–5 sec (EMT)   |
| Response type      | IBR    | Monotonic response with no oscillations exceeding the defined settling band.   |
| Voltage Recovery   | All    | Within $\pm 10\%$ in 0.5 sec, then $\pm 2\%$ steady-state within <b>ts</b>   |
| Frequency Recovery | All    | Deviation $\leq \pm 0.5$ Hz, settle within $\pm 0.2$ Hz in <b>ts</b>   |
| Power Recovery     | All    | Active/reactive power within $\pm 2\%$ of pre-disturbance after <b>ts</b>  |
| PLL Stability      | IBR    | PLL must maintain synchronism for phase jumps up to $25^\circ$   |
| Control Saturation | All    | Sustained saturation ( $> 100$ ms) shall not result in instability, limit cycling, or loss of control recoverability |

### F.3 Small Signal Response: Oscillation Assessment

Table 13: Acceptance Criteria for Small Signal Response

| Category  | Metric                              | Criteria   |
|---|-------------------------------------|--|
| Damping ratio ( $\zeta$ )<br>(0.1–5 Hz)   | $\zeta$ (dominant modes)            | $\zeta \geq 5\%$ (acceptable);<br>3–5% (marginal);<br>< 3% (unacceptable). |
| Damping ratio ( $\zeta$ )<br>(3–30 Hz)  | $\zeta$ (controller/PLL modes)      | $\zeta \geq 7\%$ (acceptable);<br>3–7% (marginal);<br>< 3% (unacceptable). |
| Settling<br>(Time domain response)  | Time to $\pm 1\%$ steady-state      | $\leq 10$ s ( $\geq 1$ Hz);<br>$\leq 30$ s ( $< 1$ Hz).                    |
| Resonance magnitude*<br>(Time domain response)  | Magnitude peak (0.1–5 Hz / 3–30 Hz) | $> +6$ dB shall trigger investigation;<br>$> +10$ dB indicates high risk   |
| Amplitude   | Voltage at POC under modulation     | $\leq \pm 5\%$   |
| * Resonance assessment must not be performed in isolation; acceptability shall be determined based on: <ul style="list-style-type: none"> <li>▪ damping characteristics; and</li> <li>▪ confirmation using EMT simulation.</li> </ul> |                                     |  |

## F.4 Small Signal Response - Benchmarking Tests

Table 14: Acceptance Criteria for Small Signal Response

| Category            | Metric                                  | Criteria  |
|---------------------|---|---|
| Linearity           | Gain/phase difference (0.03 vs 0.05 pu) | Gain $\leq$ 10%, Phase $\leq$ 7° (no limiters)  |
| EMT vs RMS          | Mode frequency match                    | $\pm$ 0.1 Hz ( $\leq$ 5 Hz),<br>$\pm$ 1 Hz ( $>$ 5 Hz)                                  |
| EMT vs RMS          | Damping ratio match                     | $\pm$ 5%  |
| Numerical           | PSCAD time-domain                       | No divergence or non-physical oscillations  |
| Control interaction | Inner vs outer loops                    | No sustained interaction leading to instability; no compound resonance; no limit cycles |

## F.5 Model Validation Against Measured Response

| Metric                            | Criteria *   |
|-----------------------------------|--|
| Steady-state error (Power)        | $\leq$ $\pm$ 5% of measured value AND<br>$\leq$ $\pm$ 2% of rated plant capacity |
| Steady-state error (Voltage)      | $\leq$ $\pm$ 0.01 pu   |
| Time alignment (Initial response) | $\leq$ $\pm$ 0.05 s  |
| Rise time difference              | $\leq$ $\pm$ 10%   |
| Settling time difference          | $\leq$ $\pm$ 10%   |

\*Acceptance criteria must be expressed using a combination of relative (%), absolute (rated capacity), and per-unit limits to ensure consistency across plant sizes.

Voltage, frequency, and power recovery behaviour must be validated against measured response and shall comply with the corresponding acceptance criteria defined in Section F.2

## Appendix G. Model Requirement Template (AO-OEM)

This appendix is provided as a high-level set of IBR modelling requirements that asset owners can provide OEMs.

### G.1 Accepted Software Version

| Software Package        | Accepted Versions               |
|-------------------------|---------------------------------|
| <b>PowerFactory</b>     | Version 2024 and above          |
| <b>DSA tools (TSAT)</b> | Version 24 and above            |
| <b>PSCAD</b>            | Version 5.02 and above          |
| <b>PSCAD Compiler</b>   | Intel Fortran Classic 2021.12.0 |
| <b>Visual Studio</b>    | Version 2019/2022               |

### G.2 Model Details

| Model type   | Project stage                   |                                  | Encryption acceptable |    |
|--------------|---------------------------------|----------------------------------|-----------------------|----|
|              | Pre-commissioning<br>(M1 model) | Post-commissioning<br>(M2 model) | M1                    | M2 |
| <b>PF</b>    | ✓                               | ✓                                | ✓                     | X* |
| <b>PSCAD</b> | ✓                               | ✓                                | ✓                     | ✓  |
| <b>TSAT</b>  | N.A                             | ✓                                | N.A                   | ✓  |

\*For assets where the PowerFactory model is considered confidential (i.e. not shareable with the industry through [the Electricity Authority's PowerFactory case files](#)), a shareable encrypted model or a generic WECC model must be provided in addition to the PowerFactory M2 model.

- Model quality requirements as mentioned in chapter 4 of this document.
- Model user guide requirements as mentioned in chapter 3 of this document.
- Model acceptance criteria as mentioned in Appendix F of this document.

## 8 Document Information

### 8.1 Metadata

#### Document ID Information

|                                  |   |
|----------------------------------|---|
| <i>Document ID number:</i>       | GL-EA-1311  |
| <i>Document Title:</i>           | Modelling Requirements for Inverter-based Resources |
| <i>Document Type:</i>            | Guideline   |
| <i>SharePoint Version:</i>       | V1  |
| <i>Document Status:</i>          | Issued  |
| <i>Severity of Consequences:</i> | Moderate  |
| <i>Frequency of use</i>          | Daily   |
| <i>Level of Risk:</i>            | Medium  |

#### DMS Structure

|  |   |   |
|--|---|---|
| <i>Macro-Process:</i>                    | Engineering Assessment (EA)                       |   |
| <i>Process:</i>                          |   |   |
| <i>Process Hierarchy:</i>                | <u>L1:</u> 01 Planning                            | <u>L2:</u> 01 Conduct Engineering Assessments |
|  | <u>L3:</u> 01-07 Conduct Commissioning Assessment | <u>L4:</u> [Business Model L4]                |
| <i>Document Complexity Rating (days)</i> | 21 days   |   |

#### Document Control

|  |                                  |                     |
|--|----------------------------------|---------------------|
| <i>Business Group Owner:</i>                               | Power Systems Group              |                     |
| <i>Prepared by (Writer/Reviewer):</i>                      | Cris Cucerzan                    |                     |
| <i>Peer Reviewer</i>                                       | [Peer Reviewer]                  |                     |
| <i>Approved by (Owner 1):</i>                              | Anna Li                          |                     |
| <i>Approved by (Owner 2):</i>                              | Click or tap here to enter text. |                     |
| <i>Approved by (Owner 3):</i>                              | Click or tap here to enter text. |                     |
| <i>Published Date: (only changed by Doc Administrator)</i> | 26/06/2026                       |                     |
| <i>Update Type:</i>  | BAU Review                       |                     |
| <i>Next Review Date:</i>                                   | 26/12/2027                       |                     |
| <i>Review Period:</i>                                      | 18 Months                        |                     |
| <i>Primary User Group(s):</i>                              | PSG                              |                     |
| <i>Secondary User Group(s):</i>                            | Click or tap here to enter text. |                     |
| <i>Hardcopy Kept in:</i>                                   | [Control Room Folder/Section]    |                     |
| <i>To be published on TP Web site</i>                      | true                             | Web Area: Public SO |