

6 Grid backbone

6.1	Introduction
6.2	Changes since the 2012 Annual Planning Report
6.3	North Island grid backbone overview
6.4	North Island grid backbone issues and project options
6.5	South Island grid backbone overview
6.6	South Island grid backbone issues and project options
6.7	HVDC link overview
6.8	HVDC link issues and project options

6.1 Introduction

This chapter describes the adequacy of New Zealand's grid backbone to meet forecast demand, anticipated generation development. Approved development plans, and further development options for the next 15 years are summarised.

The grid backbone (see Chapter 3 for more information) provides the connection between the regions. The regions are described in Chapters 7 to 19.

Prudent transmission network planning considers a range of generation scenarios to meet the forecast growth in demand (see Chapters 4 and 5 for more information) to determine the development option and timing for grid upgrades.

Transmission needs for the grid backbone are identified after the commissioning of committed projects. The identification of transmission needs is indicative only, based on a limited number of load and generation dispatch scenarios, along with the impact of future new generation scenarios. They indicate the possible need for a fuller investigation within the forecast period, with the timing and scope of the investigation determined by new generation developments and demand growth.

The resolving projects to meet the transmission needs are also indicative only, being possible solutions that will be subject to the Investment Test. They will be developed through the grid planning process as investments to meet the Grid Reliability Standard and/or to provide net market benefit.

For the North Island, the existing and possible future grid backbones are described in Section 6.3, with issues and possible grid upgrades described in Section 6.4.

For the South Island, the existing and possible future grid backbones are described in Section 6.5, with issues and possible grid upgrades described in Section 6.6.

The HVDC link is described in Sections 6.7 and 6.8. The Annual Planning Report (APR) assumed that the High Voltage Direct Current (HVDC) Pole 1 is replaced by Pole 3 in 2012/13.

6.2 Changes since the 2012 Annual Planning Report

Table 6-1 lists the specific issues and projects that are either new or no longer relevant within the forecast period when compared to last year's report.

Table 6-1: Changes since 2012

Issues/projects	Change
Transmission capacity into Auckland and Northland	NIGU project completed, most issues addressed (see Section 6.4.2)

6.3 North Island grid backbone overview

6.3.1 Existing North Island transmission configuration

The North Island grid backbone comprises the:

- 220 kV circuits from Wellington to Auckland located along the Central North Island corridor, including the recently commissioned double-circuit transmission link from Whakamaru to Auckland
- 220 kV Wairakei Ring circuits (220 kV circuits between Wairakei and Whakamaru) connecting the major hydro and geothermal generation in the Central North Island to the transmission network, and
- 220 kV circuits from Bunnythorpe to Huntly through Stratford connecting Taranaki generation to the transmission network.

Power flows either north or south on the inter-island HVDC link, depending on the time of day or year. During daylight periods and normal rainfall patterns in the South Island, power tends to flow north. In non-peak periods (late evenings and early mornings) and years of low South Island rainfall, power tends to flow south.

Figure 6-1 shows a simplified schematic of the existing North Island grid backbone.

Figure 6-1: North Island grid backbone schematic

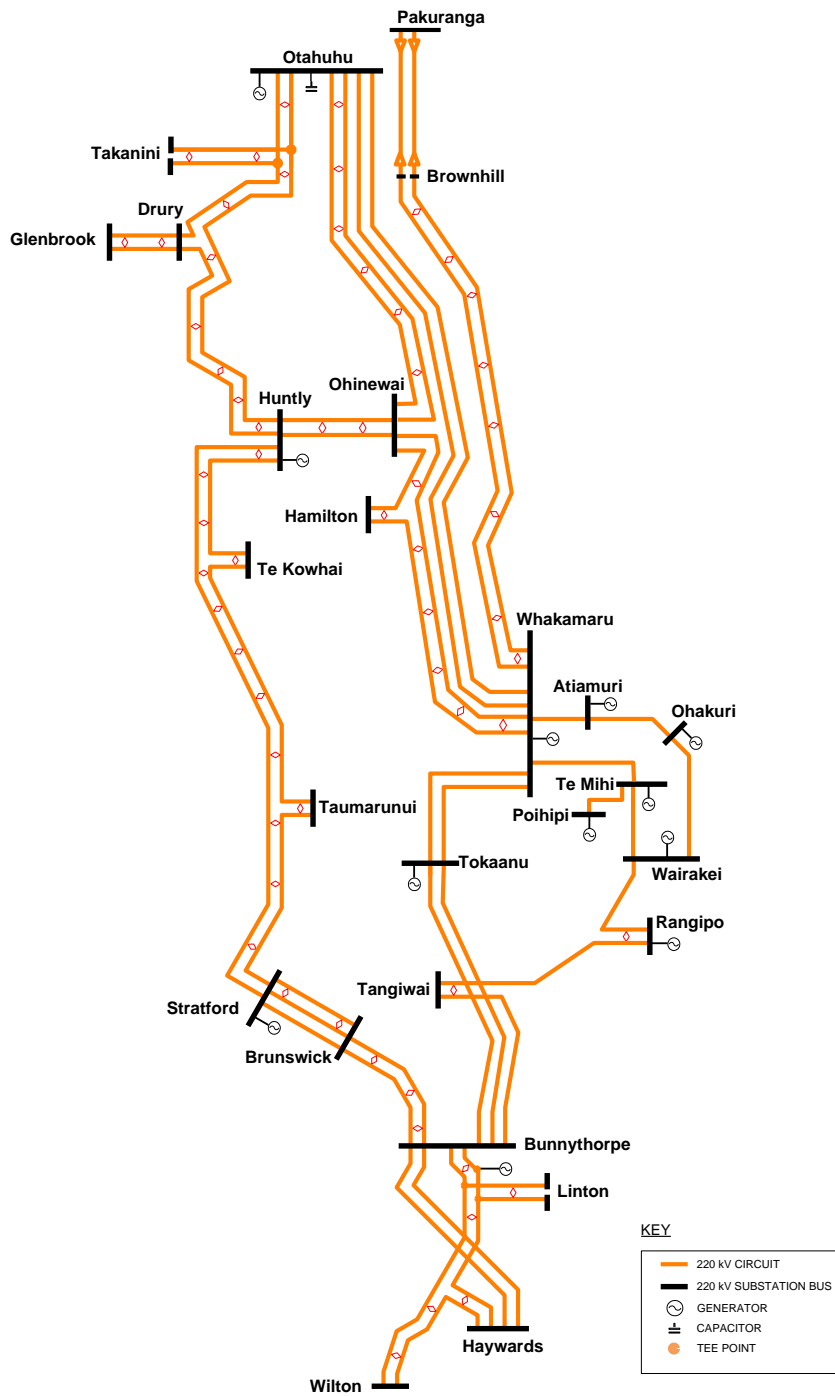

6.3.2 Future North Island grid backbone

Figure 6-2 and Figure 6-3 provide an indication of the North Island transmission backbone development in the medium-term (the next 15 years), and longer-term (beyond 2028), respectively.

We are building a new double-circuit transmission line between Wairakei and Whakamaru to replace a lower capacity, single-circuit line.

We will resubmit an Investment Proposal to the Commerce Commission to replace conductor on the existing 220 kV transmission lines between Bunnythorpe and Haywards in the second quarter of 2013. A consequence of the replacement may be an increase in the capacity on these lines.

We will also investigate an increase in transmission capacity north of Bunnythorpe, either through the Central North Island to Whakamaru, and/or through the Taranaki region and a new line to Whakamaru.

In the longer term, we may increase the transmission capacity through the North Island by increasing the operating voltage on the new overhead transmission line into Auckland to 400 kV. Ultimately we may build a new transmission line connecting Bunnythorpe, Whakamaru, and Auckland, but this is highly dependent on future load and generation growth, and the viability of alternatives.

We will also strengthen the resilience of some critical substations to high impact low probability events.

Voltage stability in the Upper North Island is an ongoing issue. We will provide additional reactive support to maintain Upper North Island voltage stability as regional load continues to grow.

Figure 6-2: Indicative North Island grid backbone schematic to 2028

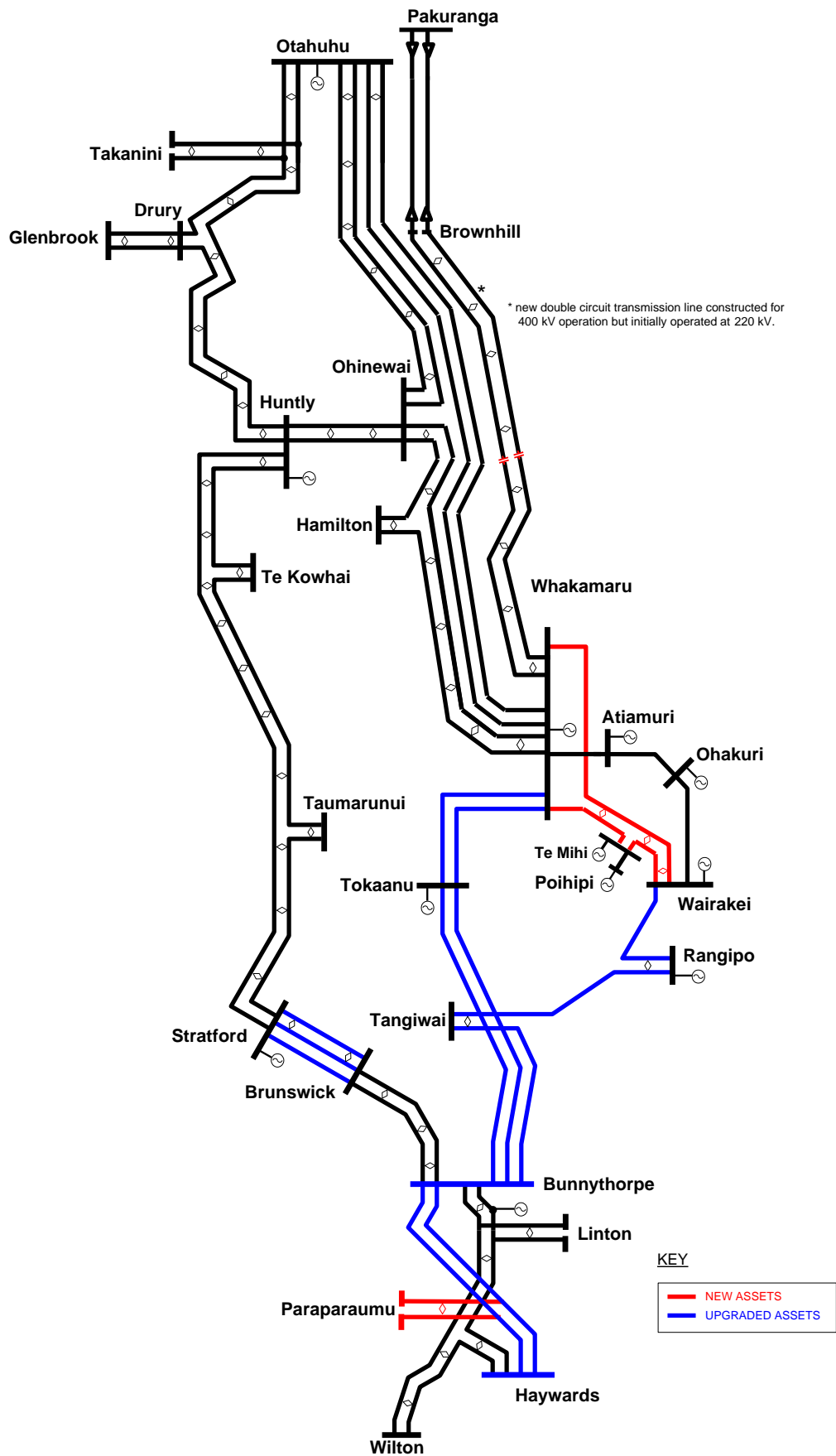
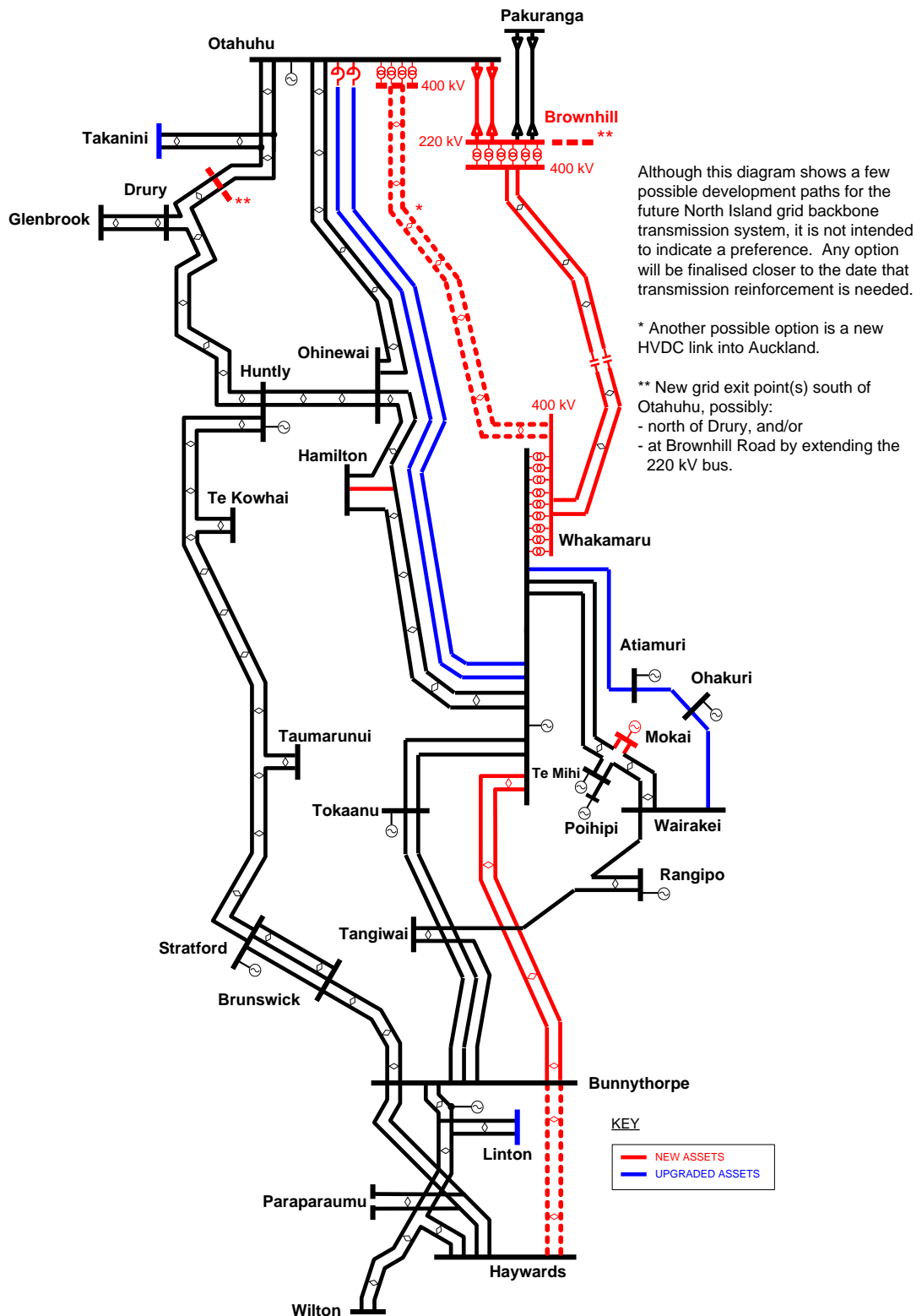

Figure 6-3: Longer-term indicative North Island grid backbone schematic beyond 2028



6.4 North Island grid backbone issues and project options

The North Island grid backbone comprises five areas indicated in Figure 6-4. Table 6-2 summarises issues involving the grid backbone for the next 15 years. For more information about a particular issue, refer to the listed section number in Table 6-2.

Figure 6-4: North Island grid backbone area

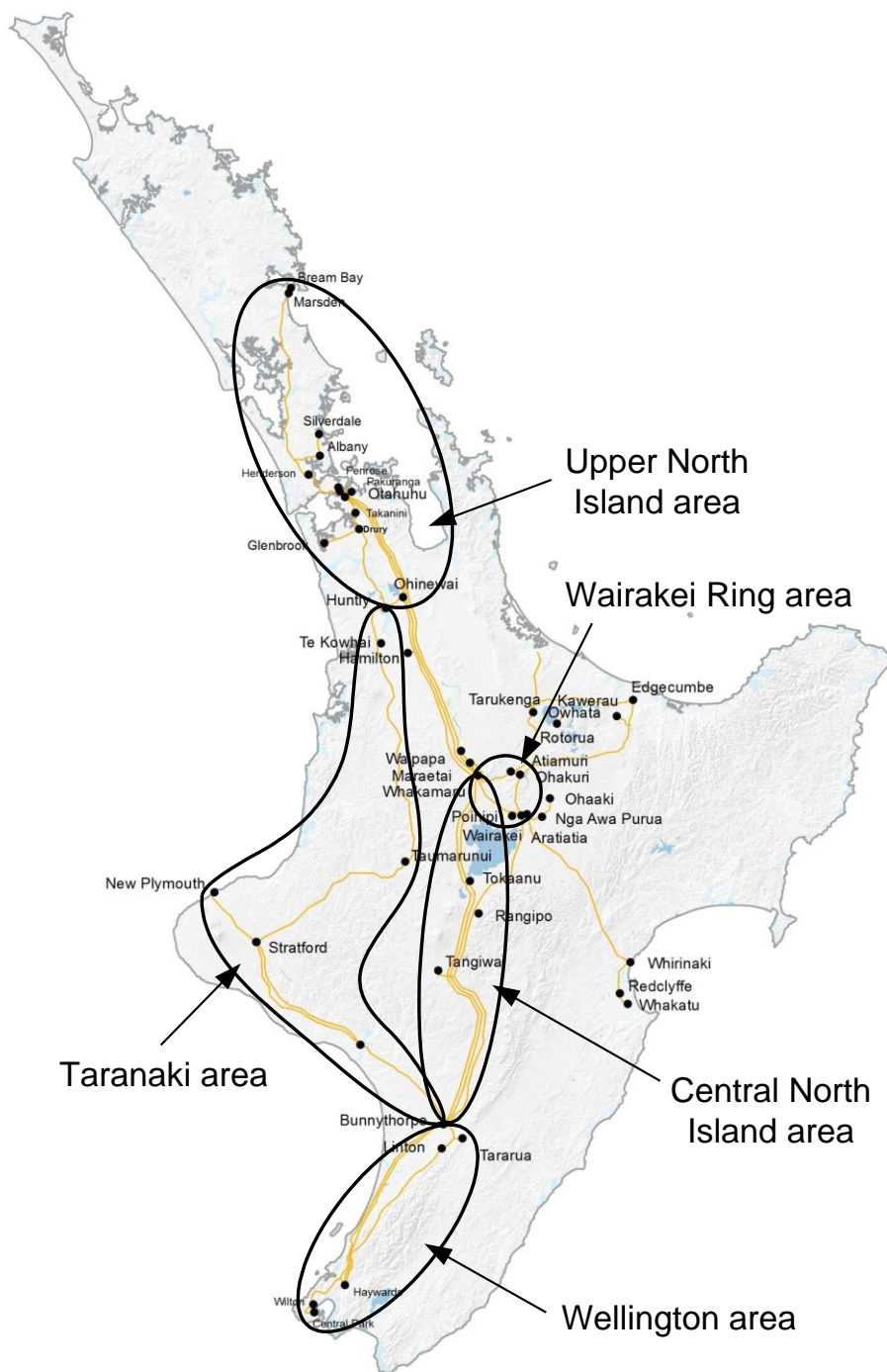

Table 6-2: Grid backbone transmission issues

Section number	Issue
6.4.1	Upper North Island voltage stability
6.4.2	Transmission capacity into Auckland and Northland
6.4.3	Wairakei Ring transmission capacity
6.4.4	Taranaki transmission capacity
6.4.5	Central North Island transmission capacity

Section number	Issue
6.4.6	Wellington area transmission capacity

6.4.1 Upper North Island voltage stability

Overview

The Upper North Island covers the geographical area north of Huntly, including Glenbrook, Takanini, Auckland, and the North Isthmus.

The transmission capability to supply the Upper North Island load is limited by voltage stability, which in turn is influenced by:

- generation in Auckland and at Huntly
- the reactive power losses due to the transmission system within the Upper North Island
- the reactive power losses due to the transmission system supplying the Upper North Island area, and
- the reactive power demand due to the composition of the load in the area (in particular the proportion and type of motor load).

There are several generator and circuit contingencies that can cause voltage control problems. The worst contingencies include the loss of the:

- Pakuranga–Whakamaru–1 or 2 circuits
- Otahuhu combined-cycle gas turbine generator
- Huntly E3P generator (Unit 5)
- 220 kV Huntly–Takanini–Otahuhu–2 circuit, or
- 220 kV Drury–Huntly–1 circuit.

The Upper North Island load includes a significant proportion of motor load. The behaviour of this load during and following faults influences the regional transmission voltage performance. During a severe fault, motors will decelerate and some can stall. The motors will then draw large currents which in turn delay the voltage recovery after a fault. We have identified that voltage recovery is most at risk in late summer between mid-January and mid-March, when the greatest amount of motor load is connected.

Reactive losses on heavily loaded transmission lines are significant, especially following a circuit tripping when the loading of parallel circuits increases.

The Upper North Island has an enduring need for voltage support because of its reliance on long transmission lines from the south for much of its power. Some component of reactive power support in the Auckland region must be dynamic to avoid the need for shunt capacitor switching after a transmission or generator contingency. The dynamic reactive support may be provided by generators, synchronous condensers, static var compensators (SVCs) or static synchronous compensators (STATCOMs).

Approved projects

Investments in previous years included an SVC at Albany, binary switched capacitors at Kaitaia, ten capacitor banks totalling 600 Mvar at four substations¹⁵, and a short-term contract for reactive support from condensers at Otahuhu¹⁶.

¹⁵ Capacitors installed in previous years are: Albany 1 x 100 Mvar, Hepburn Road 3 x 50 Mvar, Penrose 4 x 50 Mvar, and Otahuhu 2 x 100 Mvar.

We have installed power system monitoring equipment to improve our understanding of the Upper North Island power system, specifically load composition and response to transient events.

Projects approved in 2010 by the Electricity Commission under Part F of the Electricity Governance Rules include:

- a STATCOM at Penrose, scheduled for commissioning in 2013
- two STATCOMs at Marsden, scheduled for commissioning in 2014
- a Reactive Power Controller (RPC) to co-ordinate the various dynamic and static devices in the Upper North Island, scheduled for commissioning in 2015/2016, and
- demand-side participation.

We issued a Request For Proposals for demand-side participation, but the proposals received were all uneconomic. This was an unexpected result, and the demand-side participation framework is being further developed to unlock its potential (see Section 2.2 for more information).

Other approved projects also have a beneficial effect on voltage stability in the Upper North Island by reducing the reactive power losses in the transmission system.

- The North Auckland and Northland (NAaN) project that increases the transmission capacity in the Auckland and Northland regions (see Chapter 7, Section 7.8.4 for more information).
- The recently commissioned North Island Grid Upgrade (NIGU) project that increases the transmission capacity into the Auckland and Northland regions (see Section 6.4.2 for more information).

Even with these approved projects, voltage stability will be an ongoing issue.

Resolving projects

We have completed an investigation to determine the amount of additional reactive support required to relieve the Upper North Island voltage stability issue beyond the completion of the NAaN and NIGU projects. This project indicated that additional reactive support will be required within the next fifteen years. This will be a mixture of:

- shunt capacitors, in the next five years, some installed in the Northland region to also address local voltage issues (see Chapter 7 section 7.8.7 for details)
- dynamic support such as STATCOMs, in approximately ten years.

Advancing the series capacitors on the new transmission link between Whakamaru and Pakuranga will also improve voltage stability in the region.

6.4.2 Transmission capacity into Auckland and Northland

Overview

Power transfer to the Upper North Island is dependent on:

- the generation from Huntly, and the transmission capacity between Huntly and Otahuhu, and
- generation from Whakamaru and south of Whakamaru, and the transmission capacity between Whakamaru and Otahuhu.

Eight 220 kV circuits from the south primarily supply the Upper North Island, with three diverse routes, comprising:

¹⁶ The condensers belong to Contact Energy, and were once operated as gas turbine generators. The contract for the condensers expires in 2013 and will not be renewed, as it is more economic to install other reactive support such as STATCOMs.

- two circuits from Huntly to Otahuhu (the western path)
- four circuits from Whakamaru to Otahuhu (the central path), and
- two circuits from Whakamaru to Pakuranga (the eastern path).

There are also two circuits between Huntly and Ohinewai connecting the western and central paths.

The Auckland region is also connected by two smaller 110 kV regional circuits from Arapuni via Hamilton, Bombay, and Wiri to Otahuhu, though their contribution is minor compared to the 220 kV circuits.

The recently completed North Island Grid Upgrade (NIGU) project either removed or significantly reduced issues with the transmission capacity into Auckland and Northland. Issues that may still arise during periods of high demand and low generation in the Auckland area include:

- an outage of the Hamilton–Whakamaru circuit may overload the two 110 kV Arapuni–Hamilton regional circuits.
- an outage of the Hamilton–Ohinewai circuit may cause low voltage at the Hamilton 220 kV bus
- an outage of an Otahuhu 220 kV bus section may overload the Bombay–Hamilton circuits (see chapter 9 section 9.9.3)
- an outage of a Whakamaru 220 kV bus section may result in unmanageable power flows in the parallel 110 kV network.

Approved projects

The NIGU project has been recently completed. There are no other approved projects to increase the transmission capacity into Auckland and Northland.

There is a 220 kV connection between Otahuhu and Pakuranga within the Auckland region. There is also a North Auckland and Northland (NAaN) project that makes use of the transmission capacity and diversity provided by Pakuranga to increase the capacity and security within the Auckland and Northland regions (see Chapter 7, Section 7.8.4).

Figure 6-5 shows the grid backbone circuits supplying the Upper North Island area.

Figure 6-5: 220 kV Upper North Island grid backbone circuits

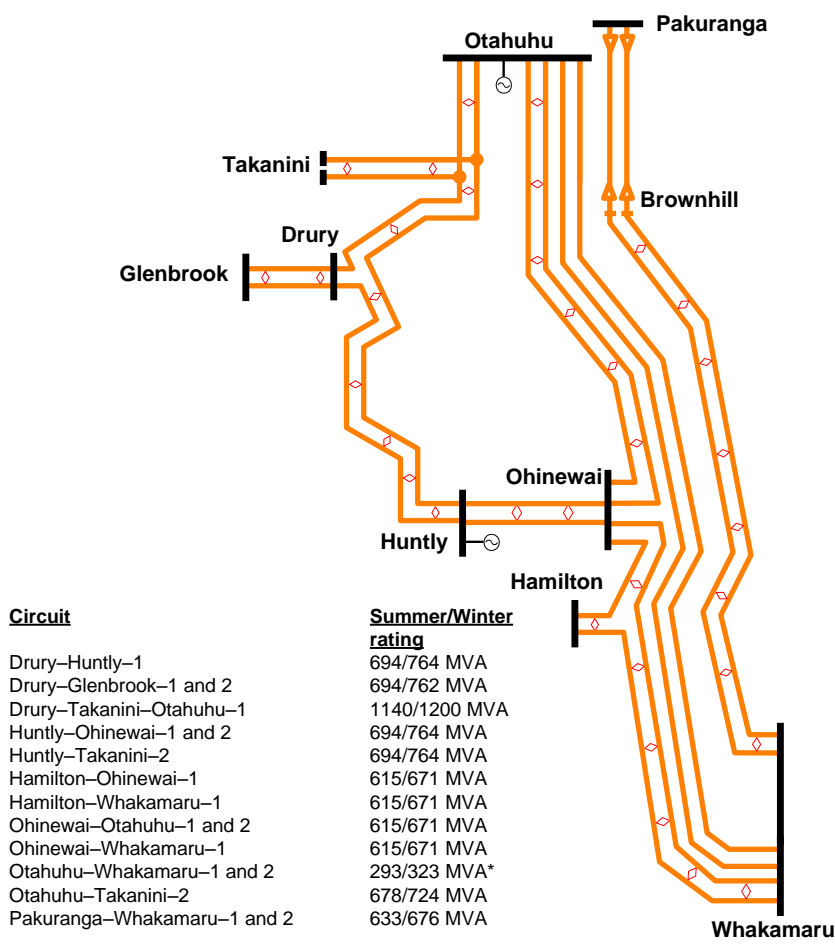

*These circuits have variable line ratings, the rating provided is the planning rating

The following sections assess the transmission capability of the circuits into the Auckland and Northland regions. The assessment is based on representative system conditions, to determine how different generation development scenarios interact with the circuits into Auckland and Northland.

System condition 1 (normal summer’s day demand)

This system condition tests a low generation scenario in the Auckland and Northland regions during a normal demand period, specifically:

- normal summer’s day load in the North Island (approximately 85% of summer peak load)
- no thermal generation in Auckland and Northland in service
- low renewable generation in Auckland and Northland, and
- medium to high generation elsewhere.

The circuits into the Auckland and Northland regions have sufficient capacity during a normal demand period and low generation in the Auckland and Northland regions for the duration of the forecast period.

However, this system condition will cause the power flows in the 110 kV network between Tarukenga and Hamilton to become unmanageable from around 2019. The worst contingency is an outage of the Whakamaru 220 kV bus section that disconnects the Atiamuri–Whakamaru and Hamilton–Whakamaru circuits.

System condition 2 (peak demand)

This system condition tests high demand in the Auckland and Northland regions along with the outage of the biggest generator, specifically:

- island peak load in the North Island
- high generation in the North Island
- the biggest generator in Auckland is out of service, i.e. Otahuhu CCGT, and
- moderate thermal generation in Northland, Auckland and Huntly.¹⁷

The Hamilton bus voltage may fall below 0.9 p.u. for the loss of the Hamilton–Ohinewai circuit towards the end of the forecast period, particularly when power flow through the Central North Island 220 kV circuits are high.

This system condition also causes the power flows in the 110 kV network between Tarukenga and Hamilton to become unmanageable from about 2024. The worst contingency is an outage of the Whakamaru 220 kV bus section that disconnects the Atiamuri–Whakamaru and Hamilton–Whakamaru circuits.

Impact of generation scenarios

The five generation scenarios described in Chapter 5 have the following impacts on the circuits into Auckland and Northland.

For system condition 1, all the generation scenarios have minimal impact within the forecast period.

For system condition 2, although the voltage at Hamilton is low for all generation scenarios, it will not fall below 0.9 p.u. as all scenarios include some additional generation in the Northland, Auckland and Waikato regions resulting in reduced power flows through the Central North Island, provided the generation is dispatched.

Outages

An outage of one of the circuits into Auckland and an outage of the biggest generator in Auckland still maintains n-1 security into Auckland and Northland.

Resolving projects

We will investigate options to resolve the Hamilton bus voltage issue closer to the time it occurs (see Chapter 9, Section 9.9.3 for more information).

We will investigate the 220 kV bus configuration at Whakamaru to confirm the most optimal configuration to manage power flows in the grid backbone and the parallel 110 kV network. Any changes are likely to be operational.

We recently completed an economic analysis to optimise the timing of series compensation on the new Pakuranga–Whakamaru circuits. This analysis showed that it may be economic to install series compensation in 2019 to minimise system losses. We anticipate commencing a more detailed investigation of this option in 2014.

Beyond 15 years, the double-circuit overhead line from Whakamaru to Brownhill will be converted from 220 kV to its construction voltage of 400 kV. This will also require:

- 220/400 kV transformers and associated works at Whakamaru substation to interconnect with the existing 220 kV system
- a switchyard in the vicinity of the transition station at Brownhill with 220/400 kV transformers and associated works

¹⁷ Generation in the Northland, Auckland and Huntly area assumed for this system condition is 690 MW at Huntly and 155 MW at Southdown.

- 220 kV underground cables to the Otahuhu substation, and
- extensions to the Otahuhu switchyard(s).

6.4.3 Wairakei Ring transmission capacity

Overview

The Wairakei Ring circuits:

- connect the major hydro and geothermal generation stations in the North Island to the grid backbone, and
- supply the Bay of Plenty region from Atiamuri and Ohakuri.

In addition, a new geothermal power station is being commissioned at Te Mihi, and a number of other generation stations which connect directly or indirectly to the Wairakei Ring are in various stages of planning or construction.

For the existing system, as this generation develops, an outage of one of the Wairakei Ring circuits may begin to constrain north power flows. Specifically, an outage of the:

- Whakamaru–Te Mihi–Wairakei circuit may overload the Wairakei–Ohakuri–Atiamuri circuits
- Wairakei–Ohakuri–Atiamuri circuits may overload the Whakamaru–Poihipi–Wairakei circuit.

Approved projects

To address the above issues, we are building a 220 kV double-circuit line between Wairakei and Whakamaru, to replace the existing single-circuit Wairakei–Whakamaru–B line. The line is scheduled for commissioning in 2013, and will increase the power flow capacity through the Wairakei Ring. We recently commissioned the new substation at Te Mihi, which will feed into this line.

Figure 6-6 shows the grid backbone circuits in the Wairakei Ring area after the commissioning of the Wairakei Ring project.

Figure 6-6: 220 kV Wairakei Ring circuits

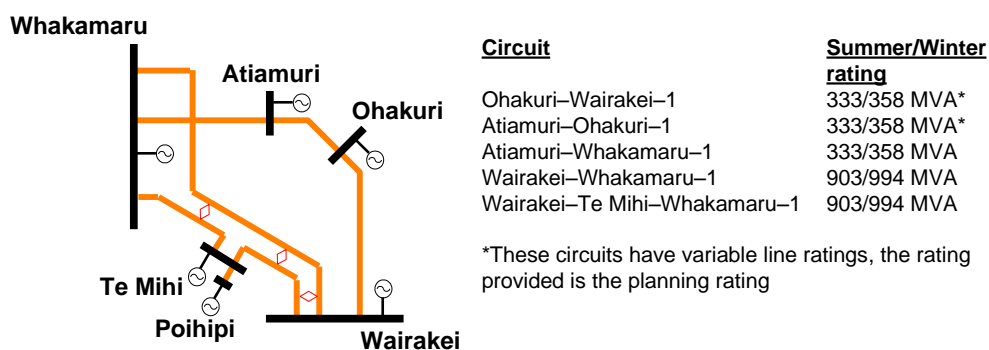

The following sections assess the Wairakei Ring transmission capability following the committed Wairakei to Whakamaru Replacement Line Project. The assessment is based on representative system conditions, to determine how different generation development scenarios interact with the Wairakei Ring.

System condition 1A (high north flow)

This system condition tests power flowing north through the circuits in the Wairakei Ring towards the Upper North Island, with power flow through the Central North Island up to the capacity of its existing transmission capacity (see section 6.4.5), specifically:

- island peak load in the North Island
- moderate thermal generation in Northland, Auckland and Huntly¹⁸
- high geothermal generation in the Wairakei Ring area
- HVDC north transfer 600 MW, and
- medium to high generation (including peakers) elsewhere to balance generation with demand (including maximum generation in Taranaki and Wellington areas).

There will be no thermal constraints if:

- the HVDC transfer and/or Taranaki generation is constrained to prevent overloading of the Central North Island circuits between Bunnythorpe and Whakamaru
- generation in the Wairakei ring does not exceed the existing committed level.

System condition 1B (very high north flow)

This system condition tests power flowing north through the circuits in the Wairakei Ring towards the Upper North Island, assuming higher transmission through the Central North Island (see section 6.4.5) is possible using variable line ratings and/or special protection schemes¹⁹, specifically:

- island peak load in the North Island
- moderate thermal generation in Northland, Auckland and Huntly²⁰
- high geothermal generation in the Wairakei Ring area
- HVDC north transfer 900 MW, and
- medium to high generation (including peakers) elsewhere to balance generation with demand (including maximum generation in Taranaki and Wellington areas).

The following issues were identified, if Central North Island transmission capacity increased:

- The Atiamuri–Ohakuri and Ohakuri–Wairakei circuits may come close to overloading for an outage of either the new Te Mihi–Whakamaru or Wairakei–Whakamaru circuits
- The Atiamuri–Ohakuri and Ohakuri–Wairakei circuits may overload for an outage of the Whakamaru 220 kV bus that connects a Tokaanu–Whakamaru and Te Mihi–Whakamaru circuits.

Also, high generation at Kawerau and low demand in the Bay of Plenty may cause higher circuit loading on the Atiamuri–Ohakuri circuit especially during high north flow through the Wairakei Ring circuits. In this scenario, the Atiamuri–Ohakuri circuit may also overload for an outage of the Edgecumbe–Kawerau circuit.

System condition 2 (south flow)

This system condition tests power flowing south through the circuits in the Wairakei Ring towards the Wellington region and the South Island via the HVDC link, specifically:

- low North Island load (approximately 45% of peak load)
- high geothermal generation in the Wairakei Ring area

¹⁸ Generation in the Northland, Auckland and Huntly area assumed for this system condition is 690 MW at Huntly and 155 MW at Southdown.

¹⁹ Using variable line rating and/or special protection schemes keeps the system impedance unchanged. Other upgrade options, such as duplexing existing lines or a new line, changes the system impedance. A change in system impedance for the Central North Island will change the overloads in the Wairakei ring.

²⁰ Generation in the Northland, Auckland and Huntly area assumed for this system condition is 690 MW at Huntly and 155 MW at Southdown.

- medium to low generation elsewhere, and
- HVDC south transfer up to 900 MW.

The Wairakei Ring circuits have sufficient capacity for south power flows for the duration of the forecast period. However, there may be transmission constraints south of the Wairakei Ring (see Section 6.4.5).

System condition 3 (east flow)

This system condition tests the ability of the Wairakei Ring circuits to supply the Bay of Plenty region during high demand and medium generation in that region, specifically:

- island peak load in North Island
- high geothermal generation in the Wairakei Ring area
- medium generation in the Bay of Plenty region with the biggest generator in the region out of service (Kawerau geothermal generator is out of service).
- medium to high generation (including peakers) elsewhere to balance generation with demand, and
- HVDC north transfer but not exceeding 1,400 MW.

The following issues were identified:

- The Ohakuri–Wairakei circuit may overload for an outage of the Atiamuri–Whakamaru, Te Mihi–Whakamaru or Wairakei–Whakamaru circuits.
- The Atiamuri–Whakamaru circuit may overload for an outage of the Ohakuri–Wairakei circuit
- The Ohakuri–Wairakei circuit may overload for the outage of a 220 kV bus at Whakamaru, Atiamuri or Wairakei.
- The Atiamuri–Whakamaru circuit may overload for the outage of a 220 kV bus at Wairakei.

Impact of generation scenarios

The five generation scenarios described in Chapter 5 have the following impacts on the Wairakei Ring circuits.

For system condition 1 (north power flow through the Wairakei Ring circuits to supply the Upper North Island), all of the generation scenarios have a substantial impact on Wairakei Ring power flows. Higher levels of power flow through the Wairakei Ring may overload the Atiamuri–Ohakuri, Ohakuri–Wairakei and Atiamuri–Whakamaru circuits. Generation scenario 1 ('sustainable path') has the most significant impact, as it has the highest net increase in the Bay of Plenty and Wairakei areas compared to the other generation scenarios.

For system condition 2 (south power flow through the Wairakei Ring circuits), all of the generation scenarios may cause overloading on the circuits between Wairakei and Bunnythorpe due to additional generation in the Wairakei Ring. Also, the Ohakuri–Atiamuri–Whakamaru circuit may overload for an outage of the Te Mihi–Whakamaru circuit, as this outage causes some power to flow from Wairakei, north to Whakamaru and then south to Bunnythorpe. Generation scenario 1 ('sustainable path') and scenario 3 ('medium renewables') have the biggest impact on power flows in the Wairakei ring for this condition.

For system condition 3 (east power flow through the Wairakei Ring), generation scenario 5 ('high gas discovery') has the highest impact on circuits supplying the Bay of Plenty region. This generation scenario has the lowest net increase in generation in the Bay of Plenty region. Therefore, there are higher levels of power flow through the Wairakei Ring to supply the Bay of Plenty region, which may overload the Wairakei–Ohakuri–Atiamuri–Whakamaru circuits.

Outages

The main connection to the Bay of Plenty region is through the Wairakei–Ohakuri and Atiamuri–Whakamaru circuits. An outage of either circuit puts the whole Bay of Plenty region on n security.

Outages of the Wairakei–Whakamaru and Wairakei–Te Mihi–Whakamaru circuits are also likely to cause generation constraints, requiring replacement generation in other areas such as the Auckland region.

Resolving projects

During peak demand periods in the Bay of Plenty region, generation must run in the region to prevent overloading of the Wairakei–Ohakuri–Atiamuri–Whakamaru circuits. Historically, generation in the Bay of Plenty region has been available during peak periods, and we expect this will continue in the short term. However, in the longer term, the region's dependence on local hydro generation may expose it to insufficient transmission capacity within the Wairakei Ring in dry years.

Transmission solutions to prevent overloading of the Wairakei–Ohakuri–Atiamuri–Whakamaru circuits include:

- variable line ratings, which will alleviate some of the overloads in the short term
- reconductoring the Wairakei–Ohakuri–Atiamuri circuits, followed by the Atiamuri–Whakamaru circuit, if required, or
- constructing a new 220 kV Wairakei–Atiamuri circuit (bypassing Ohakuri) as stage 1, followed by a second Atiamuri–Whakamaru circuit, if necessary, as stage 2.

The Wairakei–Ohakuri–Atiamuri–Whakamaru circuits have already been thermally upgraded, and a further thermal upgrade is not technically feasible. A second Wairakei–Atiamuri circuit is one option which keeps the Bay of Plenty region on n-1 security during outages of the Wairakei–Ohakuri or Atiamuri–Whakamaru circuits. It is unlikely that lack of security to the Bay of Plenty during outages will by itself provide sufficient benefit to justify the second circuit.

We will monitor the generation developments in the Wairakei Ring area and the Bay of Plenty region, to determine if a transmission upgrade investigation is required.

6.4.4 Taranaki transmission capacity

Overview

Taranaki generation is connected to the North Island grid backbone via Stratford with two 220 kV circuits north to Huntly and two circuits south to Bunnythorpe.

Figure 6-7 shows the grid backbone circuits for the Taranaki area between Bunnythorpe and Huntly.

Figure 6-7: 220 kV circuits between Bunnythorpe and Huntly

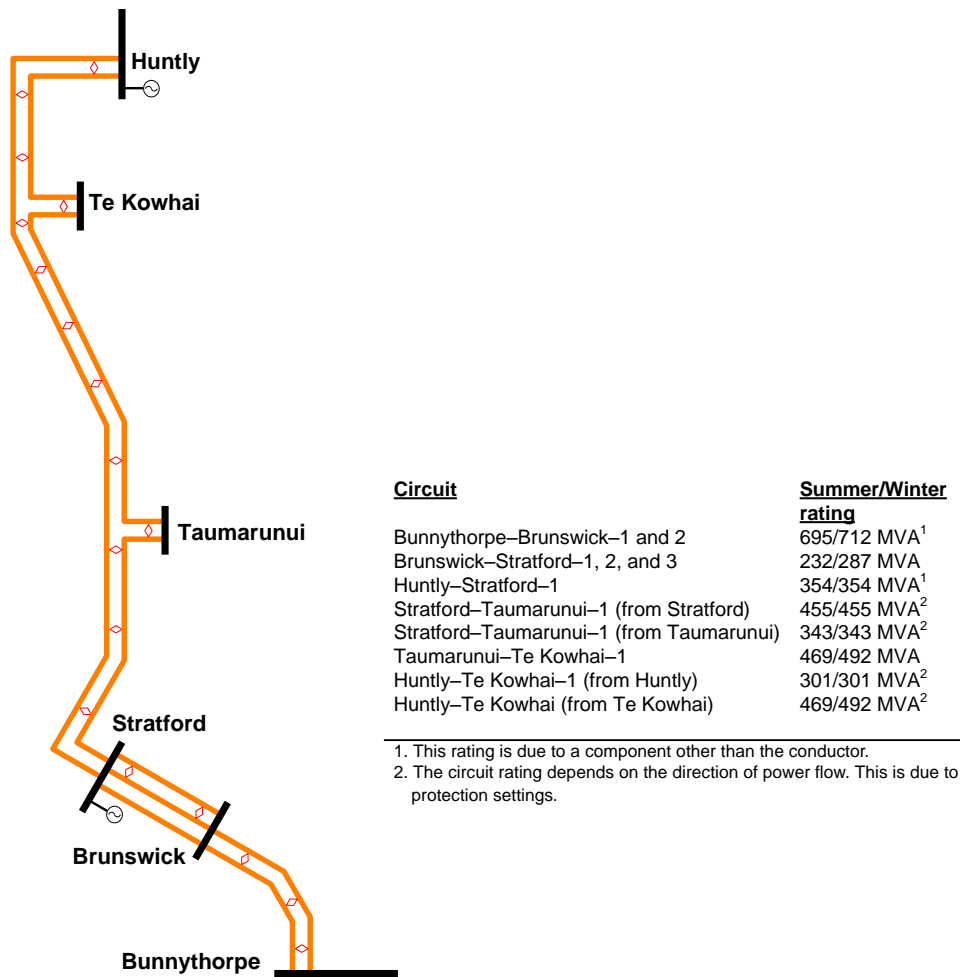

Approved projects

There are no approved grid backbone projects in the Taranaki area.

The following sections assess the Taranaki transmission capability following the committed upgrades in the North Island. The assessment is based on representative system conditions, to determine how different generation development scenarios interact with the circuits out of Taranaki.

System condition 1 (north flow)

This system condition tests power flowing north through the circuits between Stratford and Huntly to Auckland and Northland:

- island peak load in the North Island
- high generation in Taranaki
- the biggest generator in Auckland is out of service i.e. Otahuhu CCGT
- moderate generation in the Northland, Auckland and Huntly area²¹
- medium to high generation elsewhere to balance generation with demand, and
- HVDC north transfer varies between 900 MW and 1,200 MW depending on generation and demand in the North Island.

²¹ Generation in the Northland, Auckland and Huntly area assumed for this system condition is 690 MW at Huntly and 155 MW at Southdown.

For this system condition, an outage of one of the Huntly–Stratford circuits may overload the other circuit and may also lead to dynamic and transient instability.

For high levels of generation in the Taranaki area, power also flows to Bunnythorpe before flowing north through the Central North Island grid backbone²².

System condition 2 (south flow)

This system condition tests power flowing mainly south through the circuits between Stratford and Bunnythorpe to the HVDC link, specifically:

- low North Island load (approximately 45% of peak load)
- high generation in Taranaki
- medium to low generation elsewhere to balance generation with demand, and
- HVDC south transfer of between 700 MW and 1000 MW, depending on generation and demand in the North Island.

For this system condition, an outage of one of the Brunswick–Stratford circuits may overload the remaining two Brunswick–Stratford circuits²³ during summer ratings.

The 110 kV circuits between Stratford and Waverley may also overload due to the limiting station equipment at Hawera.

Impact of generation scenarios

The five generation scenarios described in Chapter 5 have the following impacts on the circuits out of Taranaki.

For system condition 1 (north power flow from Stratford to Huntly), generation scenario 5 ('high gas discovery') has the highest impact at the end of the forecast period, as it has the highest net increase in generation in the Taranaki area. The overloads on the Huntly–Stratford circuits are dependent on:

- Auckland and Northland load
- Auckland and Northland generation
- Taranaki generation, and
- lower North Island generation.

For system condition 2 (south power flow from Stratford to Bunnythorpe), all the generation scenarios have minimal impact within the forecast period on the Taranaki transmission capacity except for generation scenario 5 ('high gas discovery'). Generation scenarios 1 to 4 include the decommissioning of the Taranaki combined-cycle gas turbine while generation scenario 5 does not. This scenario has a net increase of up to 410 MW of new gas-fired peakers and combined-cycle gas turbines.

Some of the generation scenarios may result in overloads on the parallel 110 kV circuits between Stratford and Bunnythorpe.

Outages

An outage of any of the circuits out of Taranaki i.e. between Stratford and Huntly or between Stratford and Bunnythorpe, may cause generation constraints, which require replacement generation in other areas.

²² Central North Island 220 kV circuits such as Tokaanu–Whakamaru may overload during high Taranaki generation and HVDC north flow. See Section 6.4.5 for more information about this issue.

²³ Central North Island 220 kV circuits such as Bunnythorpe–Tokaanu and Bunnythorpe–Tangiawai may overload before the Brunswick–Stratford circuits overload for high HVDC south flow. See Section 6.4.5 for more information about this issue.

Resolving projects

To prevent overloading on the circuits out of Taranaki during HVDC north and south flow, the Taranaki generation can be constrained. Alternatively, transmission solutions could include:

- thermally upgrading and/or reconductoring the Brunswick–Stratford circuits
- reconductoring the Huntly–Stratford circuits²⁴, or
- constructing a new transmission line between Taumarunui and Whakamaru.

To resolve the overloads on the 110 kV circuits, we are planning to rebuild the Hawera 110 kV bus (see chapter 12 section 12.8.2 for more information).

The tuning of the generator excitation systems and power system stabilisers affects the transient and dynamic stability to transfer power out of Taranaki between Stratford and Huntly. However a stability limitation remains possible under certain system conditions particularly during circuit outages. We will monitor the generation developments in the Taranaki region to determine if a transmission upgrade investigation is required.

6.4.5 Central North Island transmission capacity

Overview

The circuits between Bunnythorpe and Whakamaru/Wairakei comprise the:

- two Bunnythorpe–Tokaanu–Whakamaru circuits, and
- Bunnythorpe–Tangiwai–Rangipo–Wairakei circuits.

Figure 6-8 shows the grid backbone circuits in the Central North Island area.

Figure 6-8: 220 kV Central North Island circuits

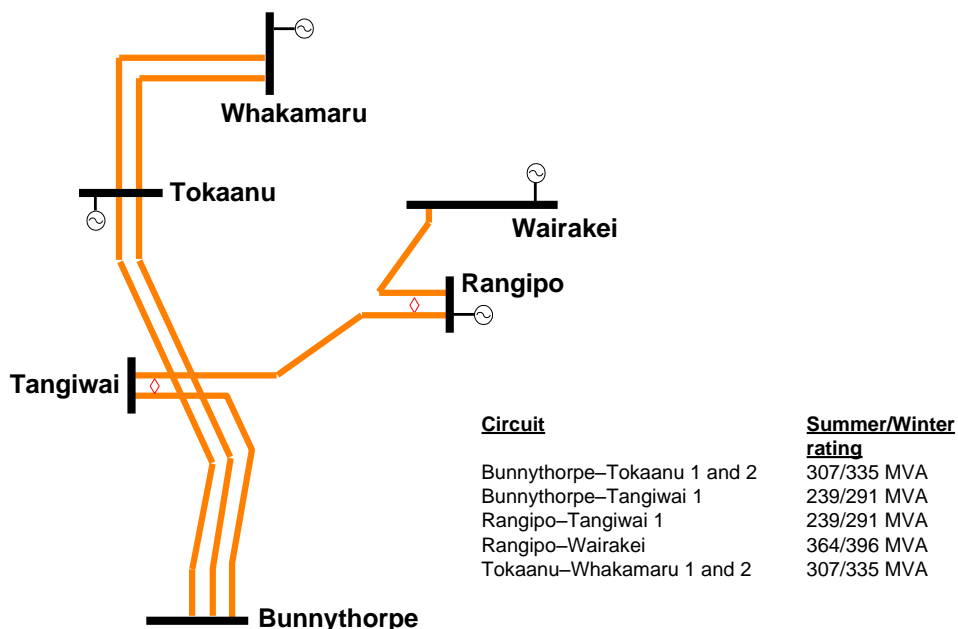

²⁴ The Huntly–Stratford circuits have a maximum operating temperature of 120°C, which is the maximum practical operating temperature. Therefore, a thermal upgrade is not possible.

Approved projects

There are no grid backbone approved projects in the Central North Island area.

The following sections assess the transmission capability of the Central North Island grid backbone following the committed upgrades in the North Island. The assessment is based on representative system conditions, to determine how different generation development scenarios interact with the circuits in the Central North Island.

System condition 1 (north flow)

This system condition tests power flowing north through the circuits in the Central North Island towards Whakamaru or Wairakei, specifically:

- island peak load in the North Island
- high renewable generation including wind, wave, tidal, and solar
- medium generation (including peakers) elsewhere to balance generation with demand, and
- HVDC north transfer varies between 600 MW and 1,000 MW depending on Tokaanu generation.

For high generation in the Taranaki area, some of the Taranaki generation flows into Bunnythorpe. This can cause an overload on the Central North Island circuits.

The following issues were identified.

- A Tokaanu–Whakamaru circuit may overload for an outage of the other Tokaanu–Whakamaru circuit, any of the Bunnythorpe–Tangiwai–Rangipo–Wairakei circuits, or one of the circuits between Stratford and Huntly.
- A Bunnythorpe–Tokaanu circuit may overload for an outage of the other Bunnythorpe–Tokaanu circuit or any section of the Bunnythorpe–Tangiwai–Rangipo–Wairakei circuit.
- The Bunnythorpe–Tangiwai–Rangipo–Wairakei circuits may overload for an outage of a Bunnythorpe–Tokaanu–Whakamaru circuit.
- The Tokaanu–Whakamaru circuits may overload for a Wairakei, Whakamaru or Tokaanu 220 kV bus outage.
- The Bunnythorpe–Tokaanu circuits may overload for a Wairakei, Bunnythorpe or Whakamaru 220 kV bus outage.
- The Bunnythorpe–Tangiwai–Rangipo–Wairakei circuits may overload for a Bunnythorpe, Tokaanu or Whakamaru 220 kV bus outage.

There is a regional 110 kV single circuit between Bunnythorpe and Arapuni (via Mataroa, Ohakune, and Ongarue) which will overload before the 220 kV circuits constrain north transfer.

System condition 2 (south flow)

This system condition tests power flowing south through the circuits in the Central North Island towards Bunnythorpe:

- low North Island load (approximately 45% of peak load)
- low renewable generation including wind, wave, tidal, and solar
- high geothermal generation in the Wairakei Ring area
- low generation elsewhere to balance generation with demand, and
- HVDC south transfer varies between 700 MW and 1000 MW depending on Tokaanu generation.

The following issues were identified.

- The Bunnythorpe–Tangiwai–Rangipo circuits may overload for outages of a Bunnythorpe–Tokaanu–Whakamaru circuit or a Wairakei–Te Mihi–Whakamaru circuit in the Wairakei ring.
- The Bunnythorpe–Tangiwai–Rangipo circuits may overload for a Bunnythorpe, Tokaanu or Whakamaru 220 kV bus outage.
- A Bunnythorpe–Tokaanu circuit may come close to overloading for an outage of the other Bunnythorpe–Tokaanu circuit or a Bunnythorpe 220 kV bus section.

There is also low voltage at Bunnythorpe, Tangiwai, and Tokaanu for high HVDC south transfer and low generation in the Lower North Island.

Impact of generation scenarios

The five generation scenarios described in Chapter 5 have the following impacts on the Central North Island circuits.

For system condition 1 (north power flow from Bunnythorpe to Whakamaru/Wairakei), generation scenario 2 ('Wind') and 5 ('high gas discovery') have the largest net increase of generation into Bunnythorpe. Scenario 2 has generation flow from the Wellington region, and scenario 5 has generation flow from the Taranaki region. The additional generation increases power flows through the Central North Island, assuming the new generation displaces thermal and hydro generation in the upper North Island, which will increase the overloading on the circuits.

For system condition 2 (south power flow from Whakamaru/Wairakei to Bunnythorpe), generation scenario 4 ('coal') has the highest impact on the circuits in the Central North Island, as it has the lowest net increase in generation in the Wellington area. With a reduced amount of new generation in the Wellington area, more power is required to flow through the circuits between Whakamaru/Wairakei and Bunnythorpe to supply demand in the Wellington area and the South Island via the HVDC link. Low voltage at Bunnythorpe, Tangiwai, and Tokaanu will also occur in later years.

Outages

An outage of any of the Central North Island circuits may cause generation constraints, which require replacement generation in other areas.

Resolving projects

For the circuits between Whakamaru and Bunnythorpe, the requirement to upgrade is largely dictated by generation development in the area. The upgrade options can be separated into two tranches depending on the amount of new generation.

In tranche 1, the range of options includes:

- limiting the power flow on 110 kV regional network between Mataroa and Ohakune through a Special Protection Scheme (SPS), series reactor or a permanent system split (putting four regional grid exit points on n security)
- reconductoring the Tokaanu–Whakamaru circuits, and
- thermally upgrading or reconductoring the Bunnythorpe–Tangiwai–Rangipo circuits.

Tranche 1 options may enable up to 500 MW of new generation (at n security) connected at or near to Bunnythorpe. The project cost falls within band F.

In tranche 2, the range of options will enable more generation beyond the options for tranche 1. The range of options includes:

- reconductoring the Bunnythorpe–Tokaanu circuits
- providing new transmission capacity between Bunnythorpe and Whakamaru by:

- reusing the existing 220 kV single circuit line route between Bunnythorpe and Wairakei for a replacement double-circuit
- constructing a new double-circuit 220 kV or 400 kV circuit between Bunnythorpe and Whakamaru, or
- constructing an HVDC 'light' link between Bunnythorpe and Whakamaru.
- Constructing a new line from Taumarunui to Whakamaru (to divert power flow from the Central North Island grid backbone), and
- Installing a Lower North Island-wide System Protection Scheme to enable new generation.

The details and range of options in tranche 2 will be investigated.

We will monitor generation developments in the Central North Island area, to determine the level of transmission upgrades required including the need for reactive devices to alleviate the low voltage issues.

6.4.6 Wellington area transmission capacity

Overview

The 220 kV circuits in the Wellington area between Bunnythorpe and Wellington comprise:

- two circuits connecting directly between Haywards and Bunnythorpe
- one Haywards–Linton–Bunnythorpe circuit, with Tararua Wind Central connected off the Linton–Bunnythorpe section of the circuit, and
- one Wilton–Linton–Bunnythorpe circuit.

Figure 6-9 shows the grid backbone circuits in the Wellington area.

Figure 6-9: 220 kV circuits in the Wellington area

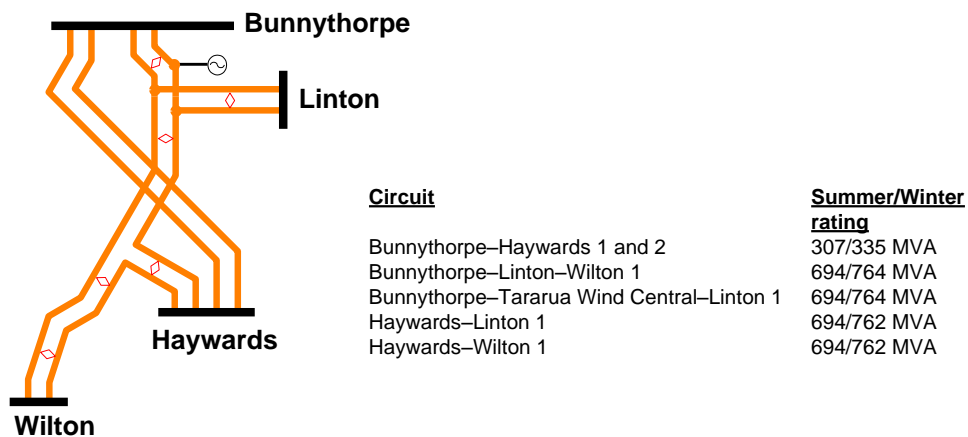

We have recently commissioned a special protection scheme on the 110 kV Bunnythorpe–Woodville circuits. This scheme enables higher HVDC transfer by reducing constraints on the parallel 110 kV network.

Approved projects

There are no approved grid backbone projects for the Wellington area.

We submitted an Investment Proposal to the Commerce Commission in December 2011 to reconductor the two direct Bunnythorpe–Haywards circuits because of condition assessment. We took the opportunity to also provide an incremental increase in the capacity of the circuits. The Commerce Commission challenged the economic justification for increasing the capacity. We are investigating alternative

options. We anticipate seeking approval from the Commission for an alternative plan in the second quarter of 2013.

The project cost falls within band F and construction is expected to be completed by the fourth quarter of 2019.

The following sections assess the Wellington area's transmission capability following the committed upgrades in the North Island. The assessment is based on representative system conditions, to determine how different generation development scenarios interact with the circuits in the Wellington area.

System condition 1 (HVDC north flow)

This system condition tests power flowing north through the circuits in the Wellington area towards Bunnythorpe, specifically:

- off-peak load in the Wellington region (between 30-90% of summer peak load)
- summer peak load in the rest of the North Island
- high renewable generation including wind, wave, tidal, and solar
- medium to high generation (including peakers) elsewhere to balance generation with demand, and
- HVDC north transfer varies between 800 MW and 1,200 MW depending on North Island generation and demand.

The following issues were identified:

- A Bunnythorpe–Haywards circuit may overload for a Bunnythorpe 220 kV bus outage.
- The regional Bunnythorpe–Woodville circuits may overload for a Bunnythorpe or Haywards 220 kV bus outage.

High power flows on the regional 110 kV circuits between Bunnythorpe–Woodville are managed with the existing special protection scheme at Woodville.

System condition 2 (HVDC south flow)

This system condition tests power flowing south through the circuits in the Wellington area towards Haywards and Wilton, specifically:

- low North Island load (approximately 45% of peak load)
- low renewable generation including wind, wave, tidal, and solar
- high geothermal generation in the Wairakei Ring area
- medium to low generation elsewhere, and

HVDC south varies between 475 MW and 900 MW depending on North Island generation and demand. The following issues were identified:

- the two Bunnythorpe–Haywards circuits may overload for outages of the Haywards–Linton or Wilton–Linton–Bunnythorpe circuits
- the Bunnythorpe–Haywards-2 circuit may overload for an outage of the Bunnythorpe 220 kV bus section that connects the Bunnythorpe–Haywards–1 and Bunnythorpe–Linton–1 circuits.

Some regional 110 kV circuits may also overload and constrain HVDC south transfer, in particular the two Bunnythorpe–Woodville circuits.

There are also voltage issues for the loss of a 220 kV circuit between Bunnythorpe and Wellington during high HVDC south transfer and low generation in the Wellington area.

Impact of generation scenarios

The five generation scenarios described in Chapter 5 have the following impacts on the circuits in the Wellington area.

Generation scenario 1 ('sustainable path'), 2 ('wind') and 3 ('medium renewables') have more than 600 MW of wind generation connected at Linton. To connect this amount of generation a 220 kV bus is required at Linton to share the generation between the Bunnythorpe–Linton–Wilton and Bunnythorpe–Linton–Haywards circuits.

For system condition 1 (north power flow from Wellington to Bunnythorpe), generation scenario 2 ('wind') has the highest impact on the circuits in the lower North Island, as it has the largest increase in wind generation at Linton (955 MW by 2028). Scenarios 1 and 2 also have a substantial increase in lower North Island generation. This increase in lower North Island generation results in the following additional circuit overloads:

- The Bunnythorpe–Tararua–Linton circuit may overload for an outage of the Bunnythorpe–Linton–1 or Bunnythorpe–Haywards circuits.
- The Bunnythorpe–Linton–1 circuit may overload for an outage of the Bunnythorpe–Tararua–Linton circuit.
- The Bunnythorpe–Tararua–Linton circuit may overload for a 220 kV bus outage at Bunnythorpe, or Haywards.
- The Bunnythorpe–Linton circuit may overload for a 220 kV bus outage at Haywards.

For system condition 2 (south power flow from Bunnythorpe to Wellington), generation scenarios 4 ('coal') and 5 ('high gas discovery') have the lowest net increase in generation in the Wellington area. With a lower amount of new generation in Wellington, more power is required to flow through the circuits between Bunnythorpe and Wellington to supply Wellington area demand and the South Island via the HVDC link

Outages

An outage of any of the 220 kV circuits in the Wellington area during HVDC north or south flow may cause generation constraints, requiring replacement generation in other areas.

Resolving projects

The impact of a 220 kV Bunnythorpe or Haywards bus contingency can be reduced through reconfiguring the Bunnythorpe and Haywards busses (see chapter 11 section 11.9, and chapter 14 section 14.9 respectively for more information).

For the two direct circuits between Bunnythorpe and Haywards, we believe that it is uneconomic to increase their rating to increase the transmission capacity (other than a possible small increase in rating following reconductoring – refer to Approved projects above). However, a higher amount of power transfer between Bunnythorpe and Haywards is possible with a Special Protection Scheme (SPS). The SPS will automatically reduce the power flowing on the HVDC link (after Pole 3 is commissioned) if the two direct Bunnythorpe–Haywards circuits overload, subject to other constraints within the power system. We will monitor the level of constraint caused by these circuits to determine when an investigation to implement an SPS is required.

The overloads on the two circuits between Bunnythorpe and Linton are driven by the amount of generation connected at Linton. We will monitor the amount of generation being connected at Linton to determine if a transmission upgrade investigation is required.

For the two regional 110 kV Bunnythorpe–Woodville circuits, we have installed an SPS to increase south-flow transmission capacity. The SPS may require expanding to include 220 kV contingencies (see chapter 11 section 11.8.3 for more details). We will monitor new generation connections to determine if an investigation to re-conductor the circuits to a higher rating is required.

There is significant potential wind generation in the Wairarapa. One option to connect this generation is to build a new 220 kV transmission line from the Wairarapa to Bunnythorpe or Linton.

6.5 South Island grid backbone overview

6.5.1 Existing South Island transmission configuration

The South Island grid backbone comprises 220 kV circuits with:

- three circuits from Islington to Kikiwa
- four circuits from Twizel and Livingstone in the Waitaki Valley area to Islington
- circuits within the Waitaki Valley, between Twizel and Livingstone, which connect six large hydro power stations and the HVDC link
- three circuits from Roxburgh to Twizel and Livingstone in the Waitaki Valley area, and
- four circuits from Roxburgh to Invercargill/North Makarewa (two via Three Mile Hill) and nine circuits within the Southland area.

Power flows either north or south on the inter-island HVDC link, depending on the time of day or year. During daylight periods, power tends to flow north to meet peak demand. However, during light load periods, power can flow south to conserve the level of South Island hydro storage, especially during periods of low hydro inflow.

Figure 6-10 shows a simplified schematic of the existing South Island grid backbone.

Figure 6-10: South Island grid backbone schematic

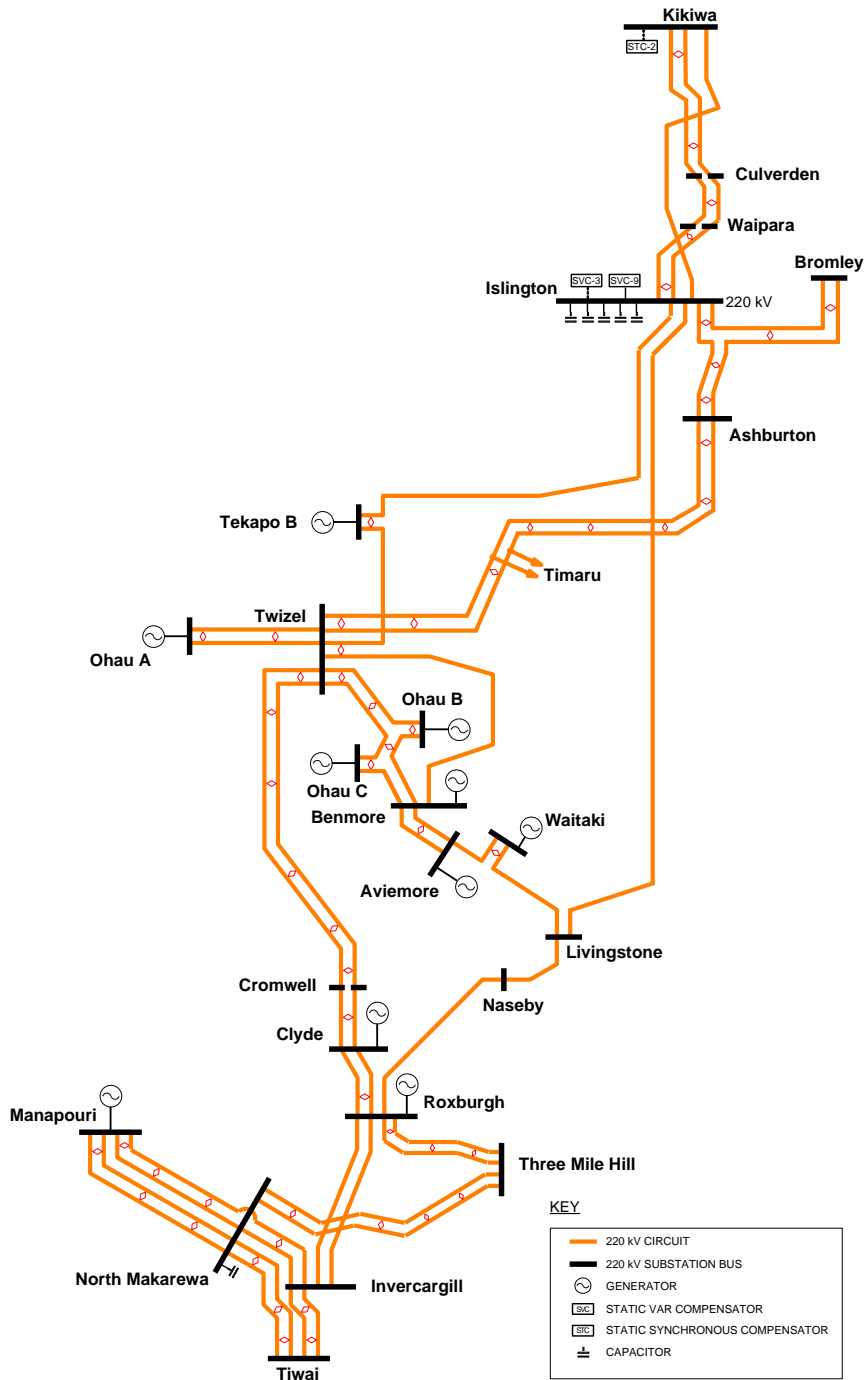

6.5.2 Future South Island grid backbone

Figure 6-11 and Figure 6-12 provide an indication of the South Island transmission backbone development in the medium term (the next 15 years), and longer term (beyond 2028), respectively.

We will install an additional bus coupler circuit breaker at Islington in 2014, to improve voltage stability for the Upper South Island following a bus fault and to increase security.

Further investments in the Upper South Island to maintain voltage stability and meet load growth will also be required. We are consulting on two options:

- increasing the dynamic reactive support at and around the Islington 220 kV bus, and
- bussing all four 220 kV circuits into the Upper South Island at Orari.

In the longer term, further upgrades for the Upper South Island may be required for voltage stability or thermal capacity reasons. Options include:

- bussing all three circuits north of Islington with an HVDC tap-off near Waipara
- constructing a second Islington–Twizel circuit providing a fifth circuit into the Upper South Island²⁵, and
- constructing a second Islington–Livingstone circuit providing a fifth circuit into the Upper South Island²⁶.

The options for a fifth circuit into Islington could be implemented in stages, with the first stage terminating at Orari (or Ashburton) and the second stage deferred for a number of years.

The Upper South Island voltage stability is an ongoing issue. We will continue to study the additional reactive support requirements to maintain Upper South Island voltage stability as regional load continues to grow.

Within the Waitaki Valley area, there is an approved project to increase the transmission capacity of the Aviemore–Waitaki–Livingstone circuits²⁷. There is also an approved project to increase the capacity of the Aviemore–Benmore circuits, which will be reviewed in mid-2013 to optimise its implementation date.

Between Roxburgh and the Waitaki Valley, there is an approved project to increase the transmission capacity of the Roxburgh–Clyde circuits²⁸. There is also an approved project to increase the capacity of the Cromwell–Twizel and Roxburgh–Naseby–Livingstone circuits, which will be reviewed in mid-2013 to optimise its implementation date.

For the area below Roxburgh, the 110 kV regional network limits the capacity of the 220 kV grid backbone. There is an approved project to remove this regional grid constraint by installing a 220/110 kV connection at Gore. There is also an approved project to further increase the grid backbone capacity by installing a series capacitor on the North Makarewa–Three Mile Hill circuit, which we have put on hold due to a decreased load forecast. We will review the need for the series capacitor in 2015 and periodically thereafter. We expect an upgrade such as a series capacitor or another option may be required in about 2020.

We will also strengthen the resilience of some critical substations to mitigate high impact low probability events.

²⁵ The second Islington–Twizel circuit could be on a new single-circuit line, or on a new double-circuit line and the existing single-circuit line dismantled.

²⁶ The second Islington–Livingstone circuit could be on a new single-circuit line, or on a new double-circuit line and the existing single-circuit line dismantled.

²⁷ Increasing the capacity of the Aviemore–Waitaki–Livingstone circuits is programmed for Q2 in 2015.

²⁸ Increasing the capacity of the Clyde–Roxburgh circuits is programmed for Q2 in 2014.

Figure 6-11: Indicative South Island grid backbone schematic to 2028

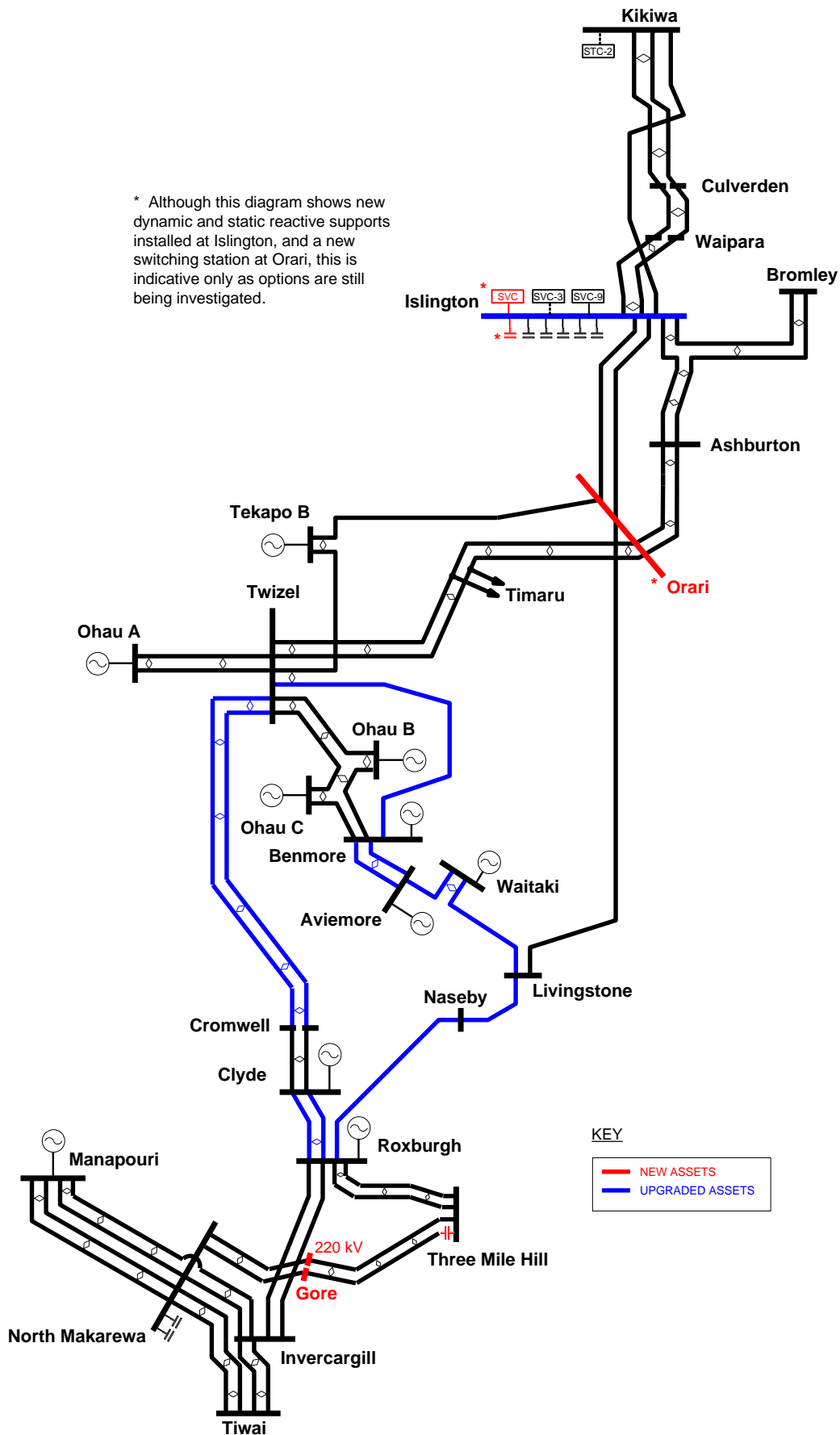
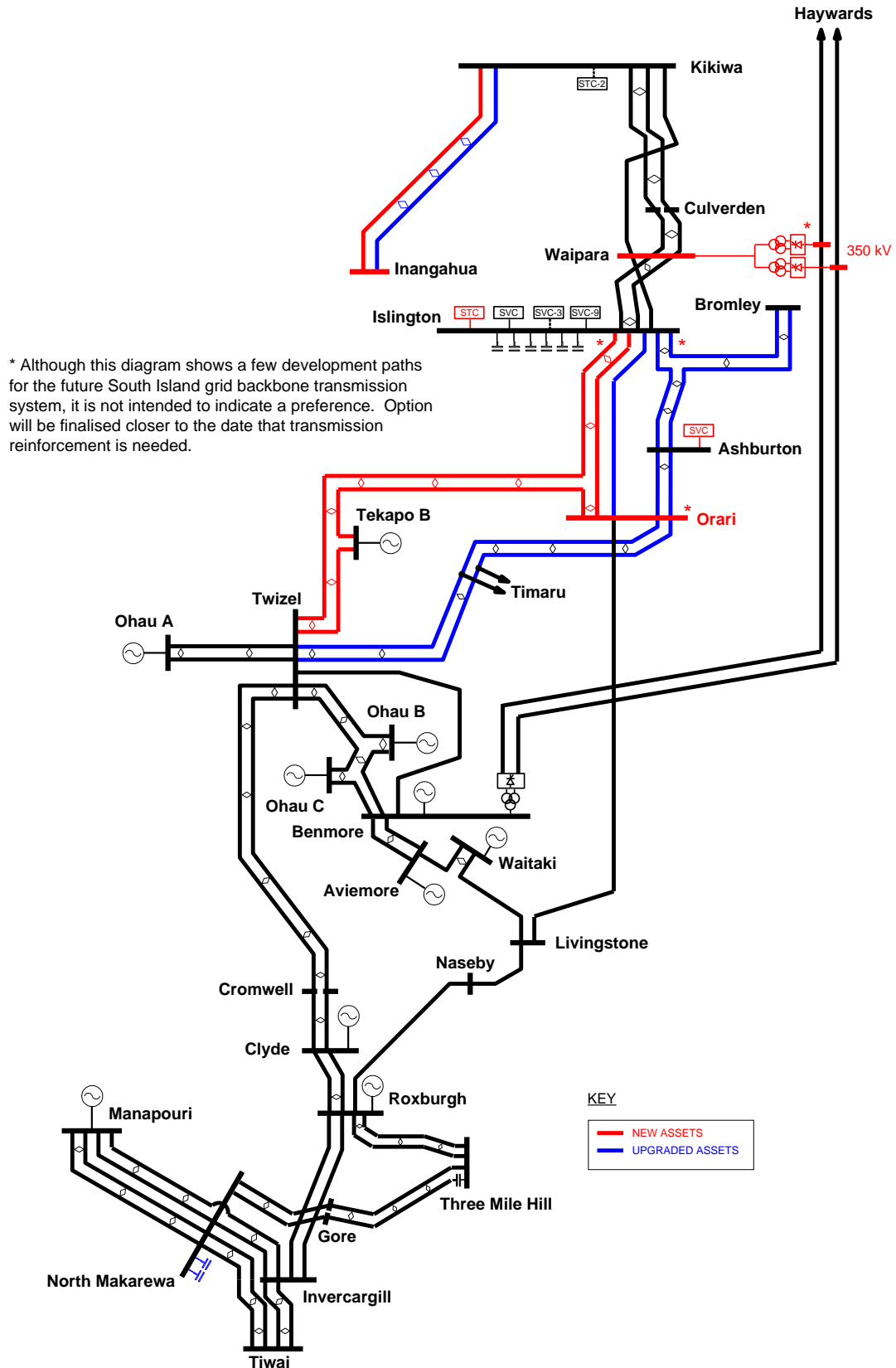

Figure 6-12: Longer-term indicative South Island grid backbone schematic



6.6 South Island grid backbone issues and project options

The South Island grid backbone comprises four areas indicated in Figure 6-13. Table 6-3 summarises issues involving the South Island grid backbone for the next 15 years. For more information about a particular issue, refer to the listed section number.

Table 6-3: South Island grid backbone transmission issues

Section number	Issue
6.6.1	Upper South Island voltage stability
6.6.2	Upper South Island transmission capacity
6.6.3	Transmission capacity north of Roxburgh and within the Waitaki Valley
6.6.4	Transmission capacity south of Roxburgh

Figure 6-13: South Island grid backbone area

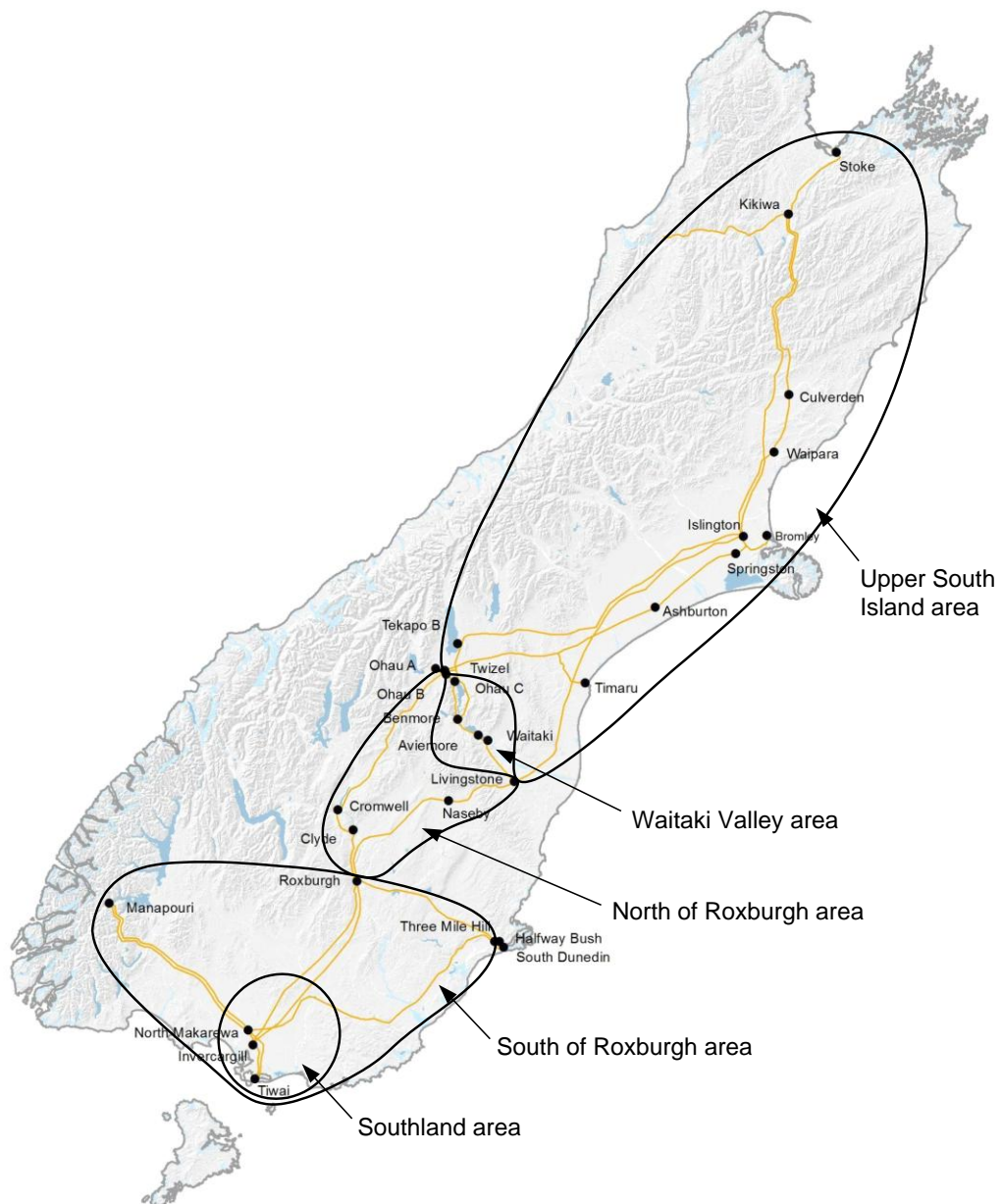

6.6.1 Upper South Island voltage stability

Overview

Most of the Upper South Island load is supplied through four 220 kV circuits from the Waitaki Valley. The Upper South Island area has relatively little generation compared with load. The generation is connected to the regional grid or embedded within the distribution networks.

The transmission capacity to supply the Upper South Island is limited by voltage stability. Voltage stability within this area is influenced by:

- the reactive power losses due to the transmission system within the area
- the reactive power demand due to load composition in the area (in particular the proportion and type of motor load), and
- generation in the area.

Reactive support for the Upper South Island is provided by:

- synchronous condensers²⁹ and SVCs at Islington
- a STATCOM at Kikiwa, and
- grid backbone capacitor banks at Islington on the grid backbone and,
- regional grid capacitor banks at Islington, Bromley, Southbrook, Blenheim, Stoke, Greymouth, and Hokitika.

The contingencies which may cause a voltage stability issue are:

- from winter 2018, an outage of an Ashburton bus section³⁰
- from winter 2019, an outage of an Islington bus section³¹, and
- from winter 2021, an outage of the Islington–Tekapo B circuit.

Approved projects

We regularly invest in grid upgrades to raise the voltage stability limit, to match load growth. We are committed to installing an additional bus coupler circuit breaker at Islington in 2014, to address Upper South Island voltage stability up to winter 2018.

Voltage stability will be an ongoing issue which will require regular investments to match load growth.

Impact of generation scenarios

The five generation scenarios described in Chapter 5 have the following impacts on the Upper South Island backbone grid.

All generation scenarios have new generation or demand side reduction within the Upper South Island. This will improve voltage stability, which may defer or replace the need for transmission investment. Generation scenarios 1 ('sustainable path'), 2 ('wind'), and 3 ('medium renewables') have the highest amount of new generation. Generation scenarios 4 ('coal'), and 5 ('high gas discovery') have the least new generation over the next five years, and would be insufficient to defer transmission investment.

²⁹ The Islington synchronous condensers will be decommissioned in 2014.

³⁰ The critical Ashburton bus section outage disconnects the Ashburton–Timaru–Twizel and Ashburton–Bromley circuits.

³¹ The critical Islington bus section outage disconnects: Islington–Tekapo–B and Islington–T7 (220/66 kV transformer).

Outages

An outage of a circuit or other transmission element for maintenance will increase the reactive power losses of the transmission system. This requires maintenance to be scheduled for a low load period, load reduction, generation to be constrained on, and/or additional investment in reactive support.

Resolving projects

We will install a sixth bus coupler at Islington in 2014 to create an additional bus zone to minimise equipment tripping following a bus fault, and so improve voltage stability.

We have also commenced an investigation to determine the amount of additional reactive support required in the next tranche of investments to relieve the Upper South Island voltage stability issue. Transmission options include:

- a combination of static and dynamic reactive support around Islington and Bromley, and/or
- sectionalising the 220 kV circuits from the Waitaki Valley to Islington by bussing them at one or two new switching stations at Orari, which may also require about 7 km of line to be upgraded or replaced.

In the longer-term, transmission options include:

- installing approximately 350 Mvar of additional reactive support by 2028, and
- reinforcing the Upper South Island transmission capacity (see Section 6.6.2), which also addresses the voltage stability issue.

6.6.2 Upper South Island transmission capacity

Overview

Power transfer to the Upper South Island is through four 220 kV circuits from the Waitaki Valley.

The Islington 220 kV bus is a single major node, supplying a large proportion of the load in Christchurch (along with Bromley), Nelson-Marlborough and the West Coast. There is a risk that high impact low probability single events at Islington can cause a significant or total loss of supply, either with all equipment in service or during maintenance outages.

Approved projects

There are no approved grid backbone projects in the Upper South Island area for transmission capacity.

System condition (north flow)

The Upper South Island has relatively little generation compared with load, even at minimum load. Therefore, power always flows from the Waitaki Valley northwards.

The n-1 transmission (thermal) limit for the Upper South Island area is forecast to bind in 2025.

Impact of generation scenarios

The five generation scenarios described in chapter 5 all have new generation north of Islington, or demand response to reduce peak demand. More generation or demand response defers the onset of the n-1 transmission limit.

Outages

“Outage windows” are required so a circuit can be taken out of service for maintenance while managing the grid to provide n-1 security. The number and duration of outage windows available for maintenance depends on the load, load management, and generation within the area. It is possible that insufficient outage windows will be available within the forecast period to enable the required maintenance, or for upgrading circuits.

Resolving projects

Options to address the n-1 transmission capacity towards the end of the forecast period include:

- an HVDC tap-off from the existing HVDC line north of Christchurch, or
- a new transmission line to Islington. This could be built in stages, terminating at Orari (if built) or Ashburton.

These resolving projects may need to be brought forward a few years to ensure there are enough opportunities to take equipment out of service for maintenance.

We will monitor the loading on the Upper South Island circuits to determine when a transmission upgrade investigation is required.

6.6.3 Transmission capacity north of Roxburgh and within the Waitaki Valley

Overview

Two sub-areas make up the grid backbone in the area: within the Waitaki Valley, and from Roxburgh to the Waitaki Valley.

The grid backbone within the Waitaki Valley connects the:

- Upper South Island area, at Twizel and Livingstone
- Waitaki Valley hydro generators³² at six substations
- inter-island HVDC link at Benmore, and
- transmission system to Roxburgh, from Twizel and Livingstone.

The direction and amount of power flowing through the circuits within the Waitaki Valley depends on the load in the Upper South Island, the generation in the area, the amount and direction of HVDC transfer, and the net Otago/Southland load.

The grid backbone from Roxburgh to the Waitaki Valley provides through-transmission to the Otago/Southland area. The direction of the power flow may be north or south, depending on the generation and load in the Otago/Southland area. The power flow within the sub-area is also significantly influenced by the generation at Clyde and, to a lesser extent, by the load off-take at Cromwell and Naseby.

Approved projects

The Clutha–Upper Waitaki Lines Project (CUWLP) is an approved suite of projects³³ to increase transmission capacity for:

- low generation in the Otago/Southland area, which causes high ‘south’ power flows from within the Waitaki Valley to Roxburgh, and
- high generation in the Otago/Southland area, which causes high ‘north’ power flows from Roxburgh to the Waitaki Valley.

³² The six hydro power stations that connect to the grid backbone in the Waitaki Valley are: Ohau A, Ohau B, Ohau C, Benmore, Aviemore, and Waitaki.

³³ The Clutha–Upper Waitaki Lines Project (CUWLP) was previously referred to as the Lower South Island Renewables Grid Upgrade Project, approved by the Electricity Commission in August 2010.

The first tranche of projects is to increase the transmission capacity to address high south power flows. We will duplex the:

- Clyde–Roxburgh–1 and 2 circuits in 2014, and
- Aviemore–Waitaki–Livingstone circuits in 2015.

Duplexing these circuits approximately doubles the south transmission thermal capacity³⁴ to export power from the Waitaki Valley to Roxburgh, (from 250-280 MW to 560-590 MW)³⁵. There is no significant change in the north transmission thermal capacity.

The second tranche of projects is to:

- duplex the Roxburgh–Naseby–Livingstone circuits
- duplex the Aviemore–Benmore–1 and 2 circuits, and
- thermally upgrade Cromwell–Twizel–1 and 2 circuits.

The primary benefit of the second tranche of projects is to increase the north transmission thermal capacity. When there is high generation in the Otago/Southland area, and at Roxburgh and Clyde, power is exported to the Upper South Island area and/or the HVDC link at Benmore. The increase in transmission thermal capacity is progressive, with increased transmission capacity available at the completion of each upgrade. The north transmission thermal capacity increases from its existing level of 200-590 MW to 790-1,260 MW³⁶ once all the upgrades are completed.

The justification for increasing the north transmission thermal capacity is twofold, to enable:

- full output from existing generators at Clyde, Roxburgh and the Otago/Southland area, and
- new generation projects in the Otago/Southland area.

The second tranche also significantly increases the south transmission thermal capacity, to 560–590 MW. However, it is expected that most of this south transmission capacity will not be required.

We will review the second tranche of projects in 2013, to optimise the timing of the upgrades.

Figure 6-14 shows the circuits in the Waitaki Valley after the upgrades.

³⁴ The increase in south transmission capacity occurs only after all the referenced circuits are duplexed; there is no significant increase in south transmission capacity with only some of the circuits duplexed.

³⁵ The amount of power that can be exported from the Waitaki Valley to Roxburgh varies with generation, particularly generation at Clyde power station, and varies to a lesser extent with load. The limits are measured across the Livingstone–Naseby and Cromwell–Twizel–1 and 2 circuits in the Roxburgh–Waitaki Valley area.

³⁶ The amount of power that can be sent from Roxburgh to the Waitaki Valley varies with generation and load. The large range for north transmission capacity is mainly due to the effect of generation at Clyde, ranging from full output of 432 MW to 0 MW. The limits are measured across the Naseby–Roxburgh and Clyde–Roxburgh–1 and 2 circuits.

Figure 6-14: 220 kV circuits between Roxburgh and Twizel after CUWLP upgrade

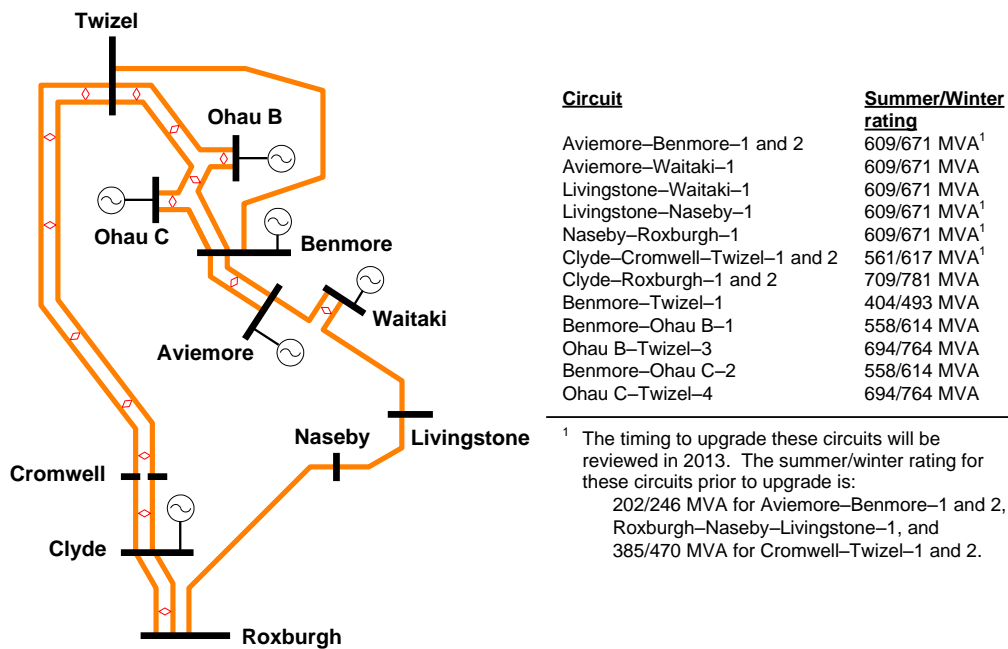

The following sections assess the transmission capability following the CUWLP upgrade. The assessment is based on representative system conditions, to determine how different generation development scenarios interact with the Waitaki Valley area.

System condition 1 (north flow)

This system condition tests power flowing from the Lower South Island to the upgraded HVDC link, specifically:

- maximum South Island generation
- off peak South Island load (approximately 65% of island peak)
- maximum HVDC north transfer of 1,000 MW

There were no issues with transmission capacity for north flow for the forecast period.

System condition 2 (south flow)

This system condition tests power flowing south of Roxburgh/Clyde during a period of extremely low southern generation, fully utilising the upgraded HVDC links south flow capacity. To avoid overloading the grid backbone (after the CUWLP projects are completed) in:

- 2018, a minimum total of about 350 MW of generation is required at Manapouri, Roxburgh and Clyde power stations
- 2028, a minimum total of about 630 MW is required at Manapouri, Roxburgh and Clyde power stations.

Impact of generation scenarios

The five generation scenarios described in Chapter 5 have the following impacts on the circuits within the Waitaki Valley area.

There were no issues with transmission capacity for north flow for all generation scenarios.

High levels of power flow south towards Roxburgh, with high levels of HVDC south flow, may overload the Benmore–Twizel circuit.

As noted in the previous section for system condition 2 (south flow), minimum levels of generation are required south of Roxburgh/Clyde. Any new generation south of Roxburgh increases the options for providing the minimum generation requirements, assisting in the management of the power system.

Outages

The transmission capacity is reduced during outages, which may require generation in the Waitaki Valley or Lower South Island area to be constrained.

Resolving projects

For very high power flows from the Waitaki Valley to the Lower South Island, the Benmore–Twizel circuit capacity will need to be increased. Transmission solutions to prevent overloading of the Benmore–Twizel circuit include³⁷:

- implementing variable line ratings to alleviate some overloads in the short term, and
- thermally upgrading and/or reconductoring the Benmore–Twizel circuit.

We will monitor the loading of the Benmore–Twizel circuit to determine if a transmission upgrade investigation is required.

Any further increase in south transmission capacity beyond that provided by the suite of CUWLP projects will require a new transmission line. We will continue to monitor the load and minimum generation levels to determine if a new line investigation is required, although there is no such need at present..

6.6.4 Transmission capacity south of Roxburgh

Overview

The grid backbone south of Roxburgh is primarily a six circuit “triangle” between Roxburgh, Three Mile Hill and Invercargill/North Makarewa. There are also nine circuits connecting Invercargill, North Makarewa, Manapouri and Tiwai.

There is a low capacity 110 kV regional network which operates in parallel with the grid backbone between Roxburgh, Halfway Bush, and Invercargill (see Chapter 19). The capacity of this regional network limits the capacity of the grid backbone.

The magnitude and direction of power flows on the grid backbone are dominated by the large hydro generation station at Manapouri and the large load at Tiwai.

The main issue for the grid backbone in this area is the transmission capacity supplying the regional load when Manapouri generation is low and Southland demand is high. An outage of one of the two Invercargill–Roxburgh circuits may result in:

- overloading of the other Invercargill–Roxburgh circuit
- low voltages in Southland, and
- overloading of the regional 110 kV network between Gore and Roxburgh and the Roxburgh 220/110 kV transformer (see Chapter 19 for more information).

These issues are presently managed by constraining on minimum levels of generation and voltage support at Manapouri.

Figure 6-15 shows the 220 kV grid backbone circuits south of Roxburgh.

³⁷ We believe that only a relatively small increase in the rating of the Benmore–Twizel circuit is required (about 20%), and that reconductoring the circuit is not required.

Figure 6-15: Grid backbone circuits south of Roxburgh

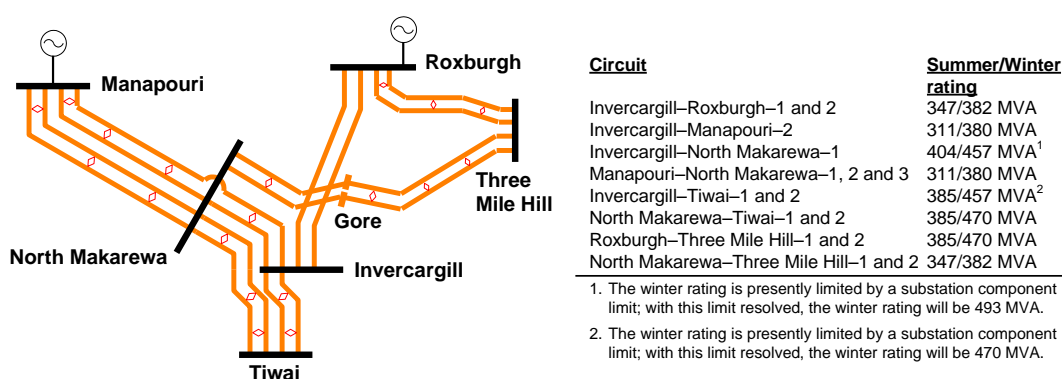

Approved projects

The Lower South Island Reliability Grid Upgrade Plan is a suite of projects to increase the grid backbone transmission capacity for power flow south from Roxburgh.

Projects to remove the constraint on the grid backbone caused by the regional 110 kV grid include (see Chapter 19 for more information):

- replacement of the Roxburgh 220/110 kV transformer with a higher rated transformer, commissioned in November 2012 (this has slightly eased, but not removed, the existing constraints),
- replacing the Invercargill 220/110 kV transformer with a transformer which has an on-load tap changer in 2014, and
- providing a 220/110 kV connection at Gore, and reconfigure the 110 kV network in 2015-2016³⁸ (this will provide a measureable increase in south transmission capacity).

There is also an approved project to further increase the south transmission capacity by installing a series capacitor on one of the two North Makarewa–Three Mile Hill circuits. We have put this project on hold due to a lower load forecast. We will review the need for the series capacitor in 2015 and periodically thereafter. We expect a series capacitor or another option may be required in about 2015.

System condition 1 (north flow)

This system condition tests power flowing north to Roxburgh, specifically:

- maximum South Island generation
- off peak South Island load (approximately 65% of island peak), and
- maximum HVDC north transfer of 1,000 MW

There are no issues with the transmission capacity south of Roxburgh during north power flow for the forecast period.

System condition 2 (south flow)

This system condition tests power flowing south of Roxburgh during periods of low generation, particularly at Manapouri. To avoid overloading of the grid backbone (after the Lower South Island Reliability upgrades are completed), increased minimum generation in the Southland area is required as the load in the area increases. In 2028, approximately 330 MW of generation will be required (principally

³⁸ The build date for the Gore 220/110 kV transformer is an estimate and is dependent on when Transpower acquires the property rights for a short length of 220 kV transmission line.

from Manapouri) to avoid overloading of the grid backbone circuits supplying the Southland load.

Impact of Generation scenarios

The five generation scenarios described in Chapter 5 have the following impacts on the circuits south of Roxburgh.

Generation scenario 4 ('Coal') connects new generation at North Makarewa (two 400 MW lignite plants in 2025, and 2028). This will cause the Invercargill–North Makarewa circuit to overload, even with all circuits in service.

Connecting new generation to one of the North Makarewa–Gore–Three Mile Hill circuits may cause the circuit to overload. Generation will not be connected to the second circuit, as this is reserved for a series capacitor³⁹.

There are no other grid backbone issues with additional generation (although all generation scenarios have 110 kV regional grid issues, see Chapter 19).

Any additional generation will assist in managing the power system during periods of low generation.

Outages

The transmission capacity is reduced during outages, which will constrain the minimum and maximum generation in the Otago-Southland area.

Resolving projects

The above issues emerge late in the forecast period.

Transmission solutions to prevent overloading of the Invercargill–North Makarewa circuit include a combination of:

- reconfiguring the grid by bussing the Invercargill–Manapouri circuit at North Makarewa
- thermally upgrading the Invercargill–North Makarewa circuit(s), possibly combined with variable line ratings, and/or
- reconductoring the Invercargill–North Makarewa circuits.

Transmission solutions to prevent overloading of the North Makarewa–Gore–Three Mile Hill circuit include:

- installing a protection scheme to automatically reduce generation if the circuit overloads
- thermally upgrading the circuits, combined with variable line rating and/or
- reconductoring of (part of) the circuit.

Any further increase in south transmission capacity following completion of the Lower South Island Reliability projects will require a new transmission line. The present load forecasts do not indicate the need for a new transmission line.

The low voltage during high levels of south transmission can be addressed by:

- increasing the rating of the existing North Makarewa capacitors from 50 Mvar to 75 Mvar⁴⁰
- installing additional capacitors
- operating Manapouri generators at 0 MW to provide voltage support.

³⁹ It is technically possible to connect generation and a series capacitor to the same circuit, but this is not normally done because of potential overvoltage and resonance issues.

⁴⁰ The two existing 50 Mvar capacitors at North Makarewa are designed to be easily upgraded to 75 Mvar.

- new thyristor based converters at Benmore and Haywards, including the associated converter transformers and DC smoothing reactors
- new 220 kV AC filters at Benmore and Haywards
- replacement of the existing 110 kV AC filters at Haywards
- refurbishment of all synchronous condensers at Haywards and new 110/11 kV transformers for four of the condensers, and
- replacement of HVDC protection and controls.

Figure 6-17: Pole 2/Pole 3 HVDC link

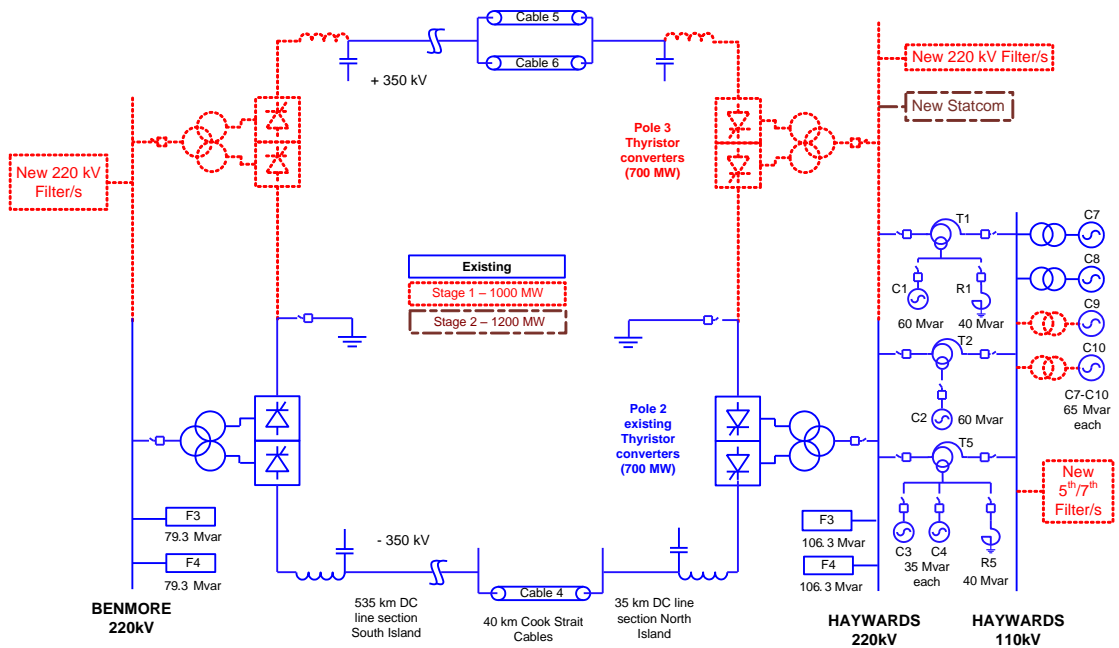
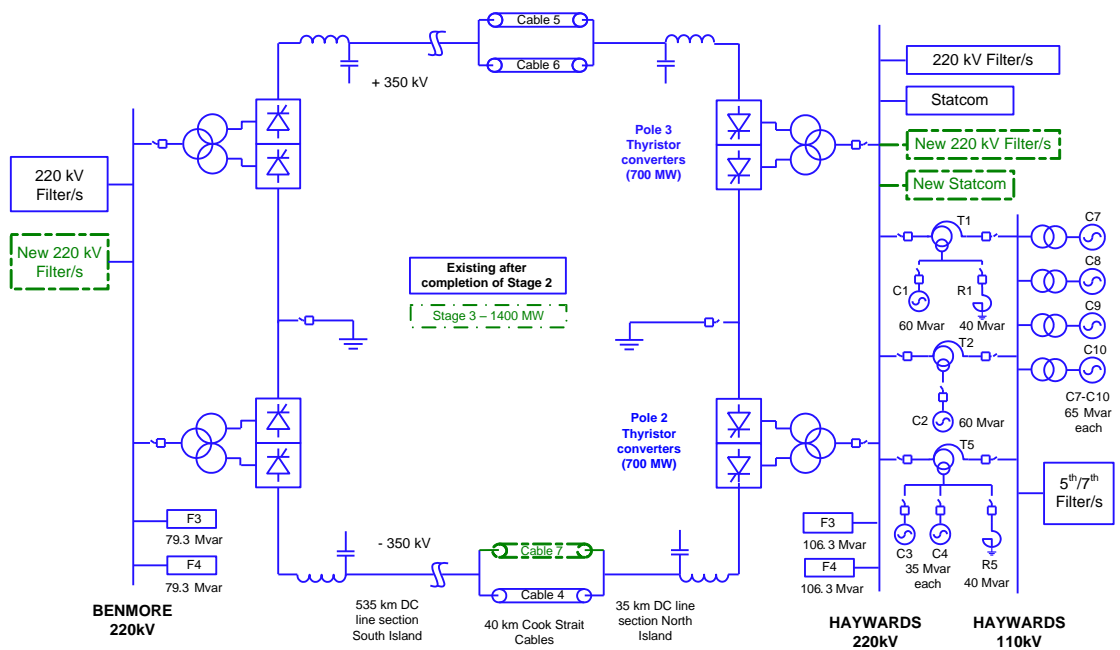

Figure 6-18 shows a simplified diagram for a possible further expansion of the HVDC link to 1,400 MW north capacity following completion of the Pole 3 project. This would involve the installation of:

- one additional submarine cable
- additional filters at both Benmore and Haywards, and
- additional dynamic reactive support at Haywards.

Figure 6-18: Possible future HVDC link



6.8 HVDC link issues and project options

6.8.1 HVDC link capacity

In 1992, the HVDC link capacity was 1,240 MW, with a Pole 1 capacity of 640 MW and a Pole 2 capacity of 700 MW.

The HVDC link capacity is now significantly lower as Pole 1 has now been de-commissioned. Pole 2 is normally available, with a maximum transfer of 700 MW. However, with only Pole 2 in operation, the HVDC link transfer is dependent on the reserve cover available, which significantly reduces the maximum practical transfer limit.

It is economic to restore the HVDC link capacity.

The Pole 3 project will provide an HVDC link capacity of 1,000 MW (north and south power flow), with a possible increase to 1,200 MW in 2014. It will not always be possible to use the full capacity of the HVDC link. Power transfer may be limited by the availability of instantaneous reserves and the capacity of the North and South Island transmission networks (refer to Sections 6.4 and 6.6 respectively).

The other sections of the Annual Planning Report assume that the Pole 3 project to replace Pole 1 is completed in 2013.

6.8.2 State of existing equipment

Pole 1

Half of Pole 1 was decommissioned in December 2009 and the second half was decommissioned on 1 August 2012.

With Pole 1 de-commissioned, HVDC bipole operation is not available. Without bipole operation, the HVDC is in monopolar operation, which results in:

- reduced HVDC capacity (one pole rather than two poles in operation)
- increased reserve cover from generation and load required for a Pole trip, and
- ground (sea/earth) return current.

For the reserve cover, in bipole operation should one pole fail then the remaining pole can increase its power transfer, which provides some self-cover. This could be partial or full load cover depending on pre-fault power flow of the remaining pole. There is no self-cover possible in monopolar operation with only HVDC Pole 2 in service.

The maximum possible transfer with only Pole 2 in service is 700 MW. However, the normal link transfer is dependent on the reserve cover available. This significantly reduces the practical transfer limit at most times.

Also, a planned or unplanned outage under monopolar operation decouples the two islands, reducing the generation available to both islands and introducing price separation (or reduced competition).

For the ground (sea/earth) return current, in monopolar operation all of the HVDC current flows in the ground.⁴¹ To date, we have not had any problems with ground return current, other than wear on the sea/earth electrodes.

Pole 2

Pole 2 was commissioned in 1991, with a design life of 35 years for the main circuit equipment, although most of the equipment is expected to last longer. Some main circuit equipment is also common to both poles (neutral bus and electrode line equipment), which was also installed in the early 1990s.

The nominal rating of Pole 2 is 560 MW, with a continuous overload of 700 MW. The continuous overload has proved very beneficial for limiting reserve requirements and managing emergency conditions.

HVDC controls

The HVDC controls and protections were installed with Pole 2 in the early 1990's. The control systems face obsolescence because their life (about 15-20 years) is shorter than that of the main circuit equipment, thus requiring at least one full replacement within the lifetime of the HVDC converter equipment.

HVDC transmission lines

The transmission line was originally built for +/- 250 kV, 1200 A operation (600 MW bipole operation). During the hybrid link upgrade, the line was re-insulated to operate at 350 kV and thermally upgraded for maximum continuous current of 2000 A. Therefore, the line is capable of 700 MW per pole or 1,400 MW bipole operation.

The conductor on a short section of the line in the North Island (Churton Park deviation) may need to be replaced within the forecast period based on condition assessment. Most of the other conductor in the North and South Islands is expected to have a remaining service life of several decades.

About 100 of the 1,530 towers in the South Island were replaced to correct conductor clearance and tower strength issues as part of line maintenance work.

HVDC submarine cables

Three cables (each rated 500 MW at 350 kV) were installed as part of the Hybrid DC link upgrade project in the early 1990s.

Between 1991 and 2004, the three cables performed well with no major issues or failures. In October 2004, a cable failed and was out of service for six months for repairs. It was fortunate that this fault was in shallow water in Oteranga Bay so it

⁴¹ In balanced bipole operation, the dc current in both poles is equal and opposite (within an accuracy of about 4 amps). Thus the current in one Pole returns through the other Pole, and the 4 amps of unbalanced current flows in the ground (sea/earth) electrode.

could be repaired using a locally available barge, with sufficient time to mobilise a repair before the limited weather window in February/March ended.

The cause of failure is difficult to establish, and the balance of probabilities indicates that it is likely to be a localised problem. However, it is also possible there is a latent design weakness or manufacturing defect which could result in another fault in the cable, or even one of the other cables.

There is a Cable Protection Zone (CPZ) to exclude external activities which might damage the cables. This is ensured by constant marine patrols preventing fishing and trawling activities within the CPZ. Regular Remote Operated Vehicle (ROV) surveys are also undertaken to monitor the external condition of the cable and the environmental factors affecting the cables.

The cables' design and the CPZ help ensure the cables will achieve or exceed their 40 year design life. However, sea conditions and seabed movement makes Cook Strait one of the most aggressive locations for submarine cables in the world. The abrasion-corrosion conditions in Cook Strait are understood and mechanical deterioration is likely to determine the life expectancy of the cables.

HVDC electrodes

A bipolar HVDC link operating with balanced current in both poles has only a small amount of residual ground current. In unbalanced bipolar operation, or in monopolar operation, a return current path needs to be provided.

The return current path is via the earth (ground), which requires a land electrode at Bog Roy, for Benmore, and a shore electrode at Te Hikowhenua, for Haywards station. These electrodes are designed for continuous operation at 2000 amps. This corresponds to 700 MW monopolar operation at 350 kV DC. It is capable of operating at 2400 A for intermittent (few hours at a time) operation.

Monopolar operation depends on the availability and integrity of the electrodes. The long term impact of operating in continuous monopolar operation at high power levels is not readily available. Since the partial and then full decommissioning of Pole 1, HVDC monopolar operation has been the normal operating mode. We and our contractors carry out regular maintenance work to ensure the integrity of the electrodes, and the electrodes remain within their design limits.

Synchronous condensers

There are eight synchronous condensers at Haywards, providing reactive support and improving system strength to enable stable operation of the HVDC link. The number of synchronous condensers that need to be in service depends on the HVDC bipole power transfer, if all other system conditions are equal.

Four condensers are connected to the tertiary windings of the 220/110/11 kV interconnecting transformers. Two condensers are connected through recently installed new 110/11 kV transformers. The other two condensers are connected to the tertiary windings of the Pole 1 converter transformers. The Pole 1 transformers are nearing the end of their reliable economic life.

The condensers were installed between 1955 and 1965 and are of very robust design and construction. Good international practice is for major overhaul and invasive maintenance every 15-20 years, which was last done in 1989-1992. In addition, much of the auxiliary equipment either no longer meets modern practice or is nearing the end of its reliable economic life.

6.8.3 Approved HVDC link projects (Stage 1 and 2)

The HVDC Pole 3 project is an approved project, presently under construction, to increase the HVDC link capacity (refer to Section 6.8.1) and address equipment issues (refer to section 6.8.2). The Pole 3 project is in two stages:

- Stage 1 provides an HVDC link capacity of 1,000 MW, and
- Stage 2 provides an HVDC link capacity of 1,200 MW.

Figure 6-17 (in Section 6.7.2) shows a simplified diagram for the two stages.

The commissioning of Pole 3 has the potential to significantly affect the operation of the power system and the electricity market. An industry group coordinates outage and commissioning activities to minimise these impacts.

HVDC converters (Stage 1 – 1,000 MW)

Pole 3 will have a nominal operating DC voltage of 350 kV and a continuous current rating of 2000 A, to give a 700 MW converter. The upper limit on the voltage is set by the existing line design and cable ratings. The maximum nominal current is limited by the line rating and the continuous rating of the new Pole 3 equipment.

A 30 minute overload capacity of 1,000 MW for Pole 3 reduces the overall system reserve requirements.

HVDC transfer north up to 1,000 MW in balanced 500/500 MW bipole operation is possible.

Pole 3 is programmed for completion in the second quarter of 2013.

Only three cables are available, which limits the self-cover of the HVDC for a pole trip:

- Pole 3 will have two cables connected, so the short-term 1,000 MW capacity of Pole 3 is matched by the 1,000 MW cable capacity, but may be limited by the steady-state 700 MW rating of the transmission line. Pole 3 will provide a minimum cover up to 700 MW for a failure of Pole 2.
- Pole 2 will have one cable connected, so the 700 MW capacity of Pole 2 will be limited by the 500 MW rating of the cable. Pole 2 will provide cover up to 500 MW for a failure of Pole 3.

As discussed in Section 6.8.1, the south transfer capability is limited by the capacity of the AC network in the North and South Islands, and varies significantly with the system demand in the Wellington region because of the AC system limitation. The HVDC controls will apply a maximum south transfer limit of 750 MW to represent this AC system limitation with all equipment in service and at a time of minimum system demand. The south transfer capability will reduce below this value as the demand increases (and during equipment outages).

110 kV filters at Haywards

The 110 kV connected filters at Haywards, installed as part of the original HVDC Link in the mid-1960s, will be replaced by 5th/7th harmonic filters.

Synchronous condensers at Haywards

The eight existing condensers will be retained and refurbished. The two condensers that are connected to the Pole 1 mercury arc valve converter transformers will be reconnected to new 110/11 kV transformers. This work is programmed for completion in the second quarter of 2014.

Pole 2 and Bipole protection and control

The Pole 2 and Bipole control systems will be replaced with identical technology to that of new Pole 3. The Pole 2 valve firing controls will be replaced as part of the new Pole 2 control system, and will interface to the existing valve based electronics (which will be retained) at the thyristors. This work is programmed for completion in the third quarter of 2013.

The new control system will be very flexible. It will monitor and control the HVDC transfer to manage system conditions at Haywards and Benmore and on the AC network at Haywards. The flexibility of the new control system will provide options to modify it, allowing the AC network to operate above the n-1 limit by relying on the HVDC control system to prevent post-contingency overloads.

Haywards STATCOM (Stage 2 – 1,200 MW)

In addition to the existing synchronous condensers, additional dynamic reactive power capacity will be required to achieve HVDC capacity greater than 1,000 MW, driven by two major functional requirements to:

- provide reactive support and improve voltage stability
- limit excessive transient or temporary overvoltage (TOV) following a bipole trip.

A STATCOM will provide the necessary dynamic reactive support for HVDC capacity of 1,200 MW. The STATCOM has a nominal rating of +60/-60 Mvar and a short-term rating which is expected to be a minimum of +100/-180 Mvar. This work is programmed for completion in the first quarter of 2014.

HVDC north transfer up to 1,200 MW is possible with unbalanced 700/500 MW operation of Pole 3/Pole 2.

Only three cables are available, which limits the self-cover of the HVDC for a pole trip as described for Stage 1.

As for Stage 1, the south transfer capability is limited by the capacity of the AC network and will vary significantly with the system demand in the Wellington region. The HVDC controls at Stage 2 will limit the maximum south transfer to 850 MW with all equipment in service and at a time of minimum system demand. The increase from Stage 1 is due to the additional reactive support provided by the STATCOM. The south transfer capability will reduce below this value as the demand increases (and during equipment outages).

HVDC line rating

Each of the poles on the HVDC line has a steady state rating of 700 MW, whereas Pole 3 will have a minimum short-term rating of 1,000 MW for 30 minutes. The full short-term rating of Pole 3 may be restricted by the rating of the line, which depends on its pre-contingency loading and ambient air temperature.

6.8.4 Further HVDC developments

HVDC link expansion to 1,400 MW

Following the Pole 3 project, the HVDC Link can be further expanded to 1,400 MW north transfer capacity with the installation of:

- one additional submarine cable
- additional filters at both Benmore and Haywards, and
- additional dynamic reactive support at Haywards.

Figure 6-18 (in Section 6.7.2) shows a simplified diagram for this possible upgrade.

The HVDC controls will limit the maximum south transfer to 950 MW with all equipment in service and at a time of minimum system demand. The increase from Stage 2 is due to the additional reactive support at Haywards. The south transfer capability will reduce as demand increases (and during equipment outages).

When planning for the additional cable, the condition and risks associated with the existing cables will also be reviewed and the need for a spare (fifth) cable will be assessed.

The timing for this possible upgrade will be assessed following completion of the Pole 3 project. The earliest anticipated date for expansion to 1,400 MW is presently 2017 and we anticipate seeking approval from the Commission in 2014. This would be a major capex proposal and our project reference is HVDC-TRAN-DEV-03.

We anticipate that a capacity increase to 1,400 MW will be sufficient to enable diversity of generation in the North and South Islands for the foreseeable future.

HVDC line rating

The HVDC line's capacity could be increased to allow the unconstrained use of the converters' short-term overload rating for all operating conditions. We will monitor the use of the HVDC link to determine if and when an investigation for an upgrade of the HVDC line may be required. This is a possible major capex proposal and we anticipate seeking approval for this project at a date to be advised. Our project reference is HVDC-TRAN-DEV-02.